

Leak Tester 3925-0075

Operating Instructions

EN 3925-0075 V0.6

Please read these instructions, **before** installing, starting up, storing or handling this device.



Any trademarks referred to in this manual are the sole property of the corresponding owner.

HeMaTech Prüftechnik GmbH & Co. KG

Siemensstrasse 7

D-71409 Schwaikheim

Telephone +49 (0) 7195/1369-0

Fax +49 (0) 7195/1369-29

© 2023 All rights reserved

Edition 05/2023

EN 3925-0075 V0.6

CONTENTS

LEAK TESTER 3925-0075	1
Operating Instructions.....	1
Introduction	7
Concerning these operating instructions.....	7
Intended use.....	8
Type plate	8
Ordering spare parts	8
Reporting transport damage	9
Preparing a return delivery	9
Warranty.....	9
Structure of the manual.....	9
Safety measures	9
Product description	10
Installation and start-up	10
Operation	10
Command reference.....	10
Maintenance	10
Signal exchange	10
Sample printouts	10
Appendix	10
The index	10
Lists.....	11
Safety measures.....	11
Safety notes.....	11
Symbols used	13
Product description.....	14
The differential pressure method.....	14
Performance characteristics	17
Design and working principle	18
Scope of delivery	18
View of device.....	19
Installation and start-up	21
Connecting peripheral equipment.....	21
Compressed air quality	22
Connecting the machine control	23
Connecting the electric power supply	25
Initialise	26
Booting process	26
The touch display.....	27
Title or menu bar	27
Working with the program	29

Command reference.....	30
Overview of menu levels	30
AUTOMATIC menu.....	31
Sequencer	33
Automatic mode without leak simulation	34
MANUAL menu	35
Test.....	36
Test without leak simulation	37
Test with leak simulation.....	38
Determination of a reference record	40
Sequencer.....	43
Sequencer enabled:.....	44
Flooding.....	44
Flooding without leak simulation.	45
SET UP menu.....	47
Test programs.....	47
Creating or changing a test program	48
Printout test programs (test parameters)	55
Copying an existing test program.....	58
Sequencer.....	59
Printout sequencer (test parameters).....	60
Interfaces.....	62
Set up the 1st serial interface.....	62
Output format File01.....	64
Output format File02.....	67
Setting up the fieldbus interface (optional)	69
Profibus	69
Profinet.....	70
Parameterisation of a test program via the fieldbus.....	75
Handshake principle.....	76
Specific parameters (pseudo parameters)	77
Processes.....	77
General start by writing a program number	77
Writing and saving of program parameters	78
Reading of program parameters	79
Deletion of test programs	79
Error detection and acknowledgment.....	80
Error codes	81
TCP/IP	82
TCP/IP v4	82
TCP/IP v6	83
VNC.....	84
USB	89
Settings menu	90
System status	90
System parameters.....	91
Software version	92
Options	93
Display.....	95
Date and time	96

Software update.....	97
Adjust pressure system	98
Error in pressure detection	99
Data	100
View Program Status	100
Data collection.....	101
Operating data	103
Data export.....	104
Data backup of test programs	104
Data import:	106
Test and set up	110
Check the test device	110
Performing the self-test	110
Performing self-test with leak	111
Setting up the device for specimen	112
Testing with filling pressure	112
Example trend measurement.....	112
Testing without filling pressure	113
Maintenance.....	114
Maintenance contract	114
Maintenance plan	114
Errors, Causes and Remedy	115
Acknowledging error messages	115
Operation mode manual	115
Automatic mode.....	115
Semi-automatic mode	115
Minimal mode	115
Trouble Shooting Chart.....	116
Signal Exchange with Machine Control.....	119
Automatic operation.....	120
Flow chart of automatic operation.....	121
Automatic operation in a time-way diagram	122
Semi-automatic operation	123
Semi-automatic in flow diagram	123
Semi-automatic operation in a time-way diagram.....	124
Minimal operation	125
Sample printouts.....	127
Protocol printout	127
Program parameters.....	128
Data collection	129
Appendix.....	130
Plug assignment.....	131
Pneumatic diagram.....	132
Data output formats	133
Examples	134

Data format fieldbus	135
Technical Data	142
List of figures.....	144
EC - Declaration of Conformity	146
Index	147
Contact address:	150
Accessories	151
Leak simulation	151
Test leak	151
Leak calibration device	152
Manual control panel	153
Performance characteristics.....	153
Switching unit	154

Introduction

In this chapter you will find some introductory remarks concerning the use of this tester, as well as explanations concerning the structure of these operating instructions and the symbols and text markings used in this manual.

The installation instructions for the device address to persons (skilled electricians and service engineers) who are entrusted with the installation and maintenance of the device. These persons must be fully familiar with and strictly follow all regulations concerning electrical engineering.

The installations for operation of the completely installed device are intended for all persons who will use and adjust the device.

Concerning these operating instructions

The following pages will inform you about the proper use of the device in your production or testing environment.

HeMaTech Prüftechnik attaches great importance to the safe, appropriate and economical use of the device. However, this requires that you read these operating instructions thoroughly before you install and use the device. It contains important information, which will help you to avoid dangers and enhance the reliability and service life of the device. Always keep these operating instructions close at hand near the device and read the chapter *Safety measures* for your own safety. Strictly follow all notes, to keep yourself and other members of staff out of danger and to avoid material damage.

If you have any questions concerning work with the device, for which you have not found an answer in these operating instructions, please contact:

HeMaTech Prüftechnik GmbH & Co. KG
Siemensstraße 7
D-71409 Schwaikheim

Telephone +49 (0) 71 95/13 69 0
Fax +49 (0) 71 95/ 13 69 29
Email info@hematech.de

www.hematech.de

Intended use

The leak tester 3925-0075 from HeMaTech Prüftechnik is solely intended for professional use in leak testing of work pieces by means of compressed air. Any use beyond these limitations is considered unintended. The user solely bears any risks.

Installation and maintenance of the device must only be performed by skilled electrical engineers.

Type plate

The type plate with model designation and serial number (Fabrik-Nr.) is located on the back of the device.

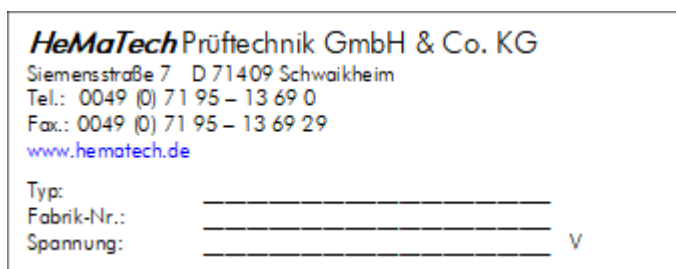

You require this information when consulting our Customer Service Department. Please record this information in the following table, so that it is at hand when needed:

Device Type	
Serial-Number:	
Software-Version	

More detailed information can also be found in the Settings/System parameters menu, see [System parameters](#)

Details about the software version can be found under Settings/Software version, see [Software Version](#)

Ordering spare parts

Use original spare parts from HeMaTech Prüftechnik only. If you would like to order accessories or spare parts, you not only need to specify device type and serial number, but also article number and designation of the required components, which you can take from the list of consumables and spare parts.

Article number:	
Designation:	

Reporting transport damage

If you discover any transport damage when unpacking the device, you should immediately contact the forwarding agent to report the loss or damage.

Please ask for a corresponding confirmation and return the package to us together with this confirmation and the delivery note.

Preparing a return delivery

Pack the article with all accessories (see scope of delivery) in the original packing material and return the goods to us, together with an exact fault description and the delivery note. Please frank the delivery.

Warranty

The warranty conditions for devices from HeMaTech Prüftechnik GmbH & Co. KG can be found in our terms and conditions of sales and delivery.

If no other agreement has been made, the warranty period for design, material and manufacturing faults (except consumables), as well as for the omission of explicitly guaranteed properties, is generally 1 year, starting from the date of delivery.

We reserve the right to decide whether we will rectify a fault, deliver replacement or submit a credit note covering the value of the goods.

In case of unintended use and damage caused by fall, water, dirt or any other external effects, warranty claims will become void.

Any malfunctions and damages caused by the user, such as soiling, faulty connections and mechanical damage are excluded from warranty.

We reserve the right to invoice the repair costs for parts which had been returned for warranty repair, but for which no or only partial warranty could be claimed.

If not agreed upon differently beforehand, HeMaTech Prüftechnik will only bear the shipment costs for outgoing deliveries of devices and parts which are covered under warranty.

However, if the delivery arrived with costs for HeMaTech Prüftechnik, these costs will be added to the repair costs.

Import and/or export duties as well as costs arising for third parties must be borne by the customer.

Structure of the manual

This manual contains the description as well as instructions for installation and operation of the device. It consists of the following chapters:

Safety measures

Read and follow these safety measures, because they serve the safety of persons and ensure the reliability and operational safety of the device.

Product description

Here you will become familiar with the device and its modules, functions and control elements.

Installation and start-up

You must prepare the place of use for the device and provide the necessary supply connections.

Operation

Once all preparations have been made switch on the device, set the test parameters and start the test device.

Command reference

Here you find a complete description of the control software with all possible settings.

Maintenance

Apart from the list of maintenance intervals, this chapter also contains the trouble shooting table with information on faults, causes and possible remedy.

Signal exchange

This section shows which signals are used in operation with a machine control system.

Sample printouts

In this section you find some examples for printouts of measurements, parameters, etc.

Appendix

This chapter contains wiring diagrams and technical data of the device.

The index

The index helps you to find required text passages quickly.

Representation

Bold type

Designations of control keys are printed **bold**.

Italic type

Cross-references to other chapters or text passages are printed *italic*.

Operating steps

Operating steps are marked as follows:

- Turn key switch clockwise. Write protection is disabled, entries can be made.
- Make the following entries and save individually or at the end by pressing the diskette symbol.



Lists

Lists are marked as follows:

- Variant A
- Variant B
- Variant C
- ...

Safety measures

Safety notes

Thoroughly read and strictly follow these safety notes. They serve your own safety, the safety of other members of staff and help to avoid damage to the device and accessory parts.

Danger caused by electric current

Make sure that no fluid can enter the control cabinet, control panel or other parts of the housing. If this should happen, immediately disconnect the device from the electric power supply, secure the corresponding socket against reconnection and inform appropriately trained expert personnel or the customer service department of HeMaTech.

Make sure that the electrical connecting leads are free of damage and well protected against bending or crushing. If you detect any damage, immediately disconnect the device from the electric power supply, secure the corresponding socket against reconnection and inform appropriately trained expert personnel or the customer service department of HeMaTech.

Work in the electrical system – e. g. changing fuses – must only be performed by trained expert staff. Further maintenance and repair work must only be performed by the customer service of HeMaTech Prüftechnik or by persons who have been authorised by HeMaTech Prüftechnik.

Use this device and any connected devices only on a dedicated electric voltage.

Strictly follow all warnings and instructions given on the device.

If smoke or pungent smells causes suspicion of a defect, you should disconnect the device from the mains supply and from any other equipment.

Take care that no other objects find their way to the inside of the device. These may come in contact with live parts or cause a short-circuit, which in turn could cause a fire or electric shock.

Before starting cleaning work disconnect the device from the mains supply and from all other devices. Use only a slightly damp cloth to clean the device, do not use fluids and sprays!

Disconnect the device from the mains supply if it is not to be used for a longer period of time. Store the device only in dry and weather protected rooms.

If safe operation of the device can no longer be assured, you must disconnect the device from the mains supply and secure it against being switched on again unintentionally.

Risk-free operation is, for example, no longer possible,

- if device or supply lead are visibly damaged,
- if the device does not work properly,
- if the device was exposed to moisture or rain,
- if condensation water has accumulated,
- if objects have found their way into the device,
- if the device does not work properly, despite orderly performed operating steps,
- if the permissible storage or operating temperature is exceeded or fallen short of.

Installation

The installation measures described in this manual must only be carried out by trained specialists. The applicable regulations for electrical engineering must in any case be observed and complied with.

The device must stand in a firm position, protected against vibration.
Avoid locations near heating or air conditioning systems.

Only install the device inside a control cabinet if adequate ventilation is assured.

Operation

Ensure unrestricted circulation of air around the device. In case of insufficient ventilation, the device will overheat. This may result in severe damage to the device and further material damage.

Maintenance

The maintenance work described in this manual must only be carried out by trained specialists. The applicable regulations for electrical engineering must in any case be observed and complied with.

Only perform the maintenance work described in this instruction manual. Any work beyond these limitations can cause damage to persons, material or device.

Repair

Do not carry out any repair work that is not explicitly permitted in these operating instructions. Consult the customer service department of HeMaTech Prüftechnik GmbH & Co. KG. Unprofessionally performed work can cause damage to persons, material or device.

Symbols used

Thoroughly read and strictly follow these safety notes. They serve your own safety and will help you to avoid damage to the device.

**DANGER!**

This safety note points to dangers, which could cause fatal injuries or severe damage to persons.

**ATTENTION!**

This safety note draws the attention to dangers, which could cause material damage or incorrect tests.

**NOTE!**

This symbol highlights hints and special features, which will ease the operation of the leak tester.

Product description

The Leak Tester is a device for pneumatic and thus non-corrosive leak testing of series production parts, such as fittings, pump housings, cylinder blocks, vacuum controls, batteries and many more. Its function is based on the differential pressure method.

The differential pressure method

This method is particularly suitable for use in series production because it can be easily automated with sufficient accuracy.

The test medium is low cost compressed air. Due to its low viscosity, it can pass through existing porosities and other leakage points with sufficient accuracy. The test does not generate any dirt. Cleaning and drying as well as corrosion protection measures are not required. Maintenance of the measuring system is unproblematic. Prerequisite for this method is the leak tightness of measuring system and testing device.

As already indicated by the name differential pressure method, the pressure difference in the measuring branch caused by a leak in the specimen is compared with the pressure in the blocked off reference path.

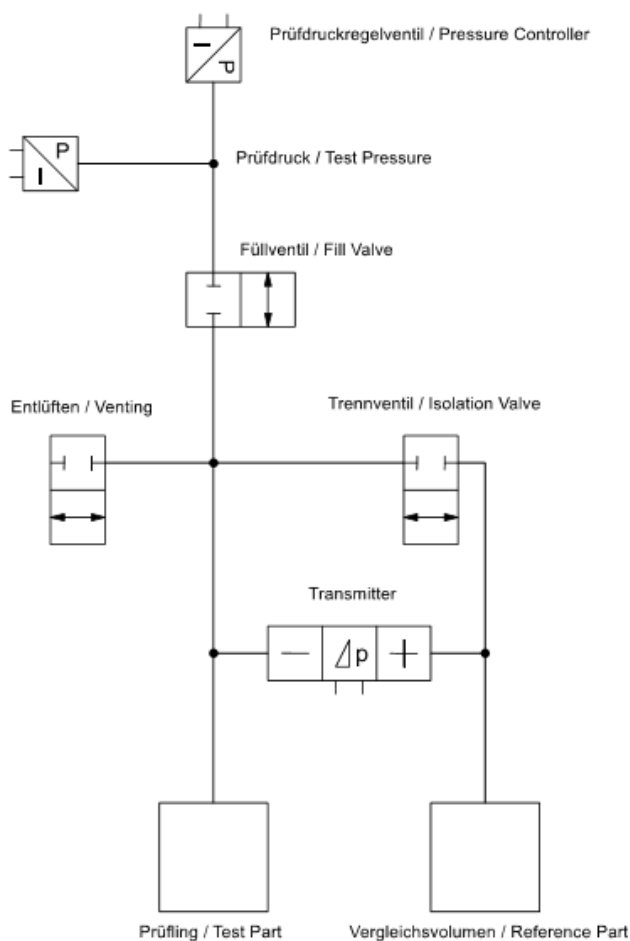

Figure 1: Function schematic of differential pressure test

The testing process consists of three phases:

1. Filling

With the filling and isolating valve open, the testing pressure set on the pressure regulator is applied to reference volume, measuring transducer and specimen. The filling time is determined by the performance of the pressure regulator, the total volume of the facility including testing and reference volume, the piping resistance and the cross-section of the valves.

2. Stabilising

This is the phase of pressure and temperature stabilisation in the entire system. The reference volume shown in the illustration – one normally uses a pressure Accept original work piece – serves the purpose of creating the highest possible symmetry level between testing and reference circuits. This enables a reduction of stabilisation time, because possibly existing interfering influences affect both circuits of the system and thus reduce the effect on the measuring result.

3. Measuring

The actual measuring phase starts after the stabilisation time has expired. By closing the filling and isolation valves the measuring and references paths are separated from each other. If the specimen has a leak, the pressure in the measuring path will drop in comparison to the reference path. The measuring transducer shows the resulting pressure difference in the measuring value display. If the pressure difference exceeds the preset limit value during the measuring phase, a signal *Reject* will be submitted, and the test stopped.

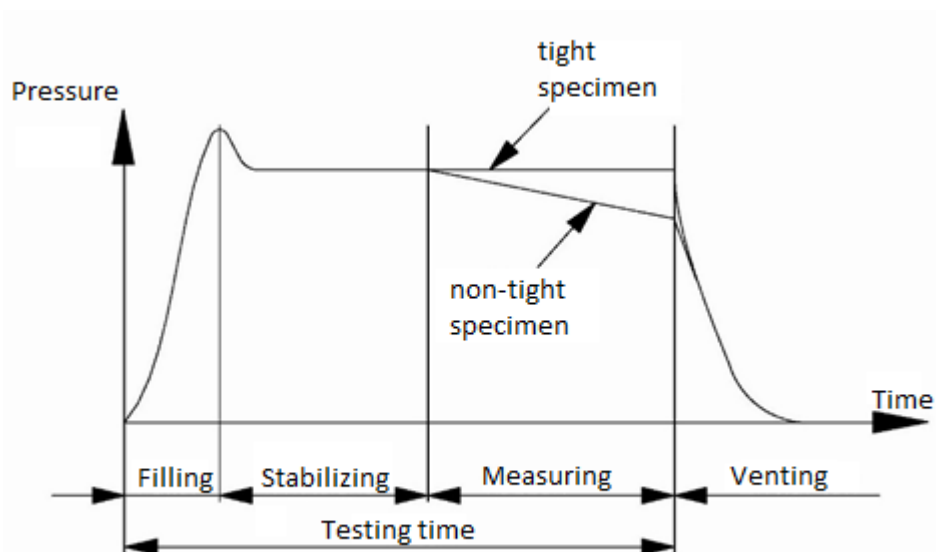

Figure 2: Pressure course in the test system during the test process

The isolating valve shown in the illustration is an isolating valve which has been specially developed for leak testers from HeMaTech Prüftechnik. The special requirements for leak testing were already accounted for in the development of the valve.

Due to the symmetric design, both measuring paths are simultaneously isolated from each other when closing the valve. Volume and pressure differences therefore act uniformly on both measuring paths, whereby measuring faults are ruled out. By distinct separation of both measuring circuits, measuring errors caused by leaks in upstream filling valves are reliably prevented. The isolating valve is pneumatically controlled and heating, caused by e. g. the coil of a solenoid valve, is thus avoided.

Leak testing equipment using the differential pressure method is well established in series production. A vast variety of work pieces and assemblies, ranging from ball-point cartridges to vehicle engine blocks, are reliably tested for leaks.

Performance characteristics

The test device offers the user several functions and possibilities to set parameters for measurements, as well as for the output and distribution of these measuring results:

Function monitoring

The device takes over the monitoring of parts and function sequence. The user receives error messages through the plain text display and floating contact.

99 test programs

There is a possibility to create up to 99 different programs and to select these either via the control panel, or by means of external signals (BCD, 8 bit) in automatic operation.

Data exchange

All test parameters and measuring results can be output, printed or processed further by PC through the serial interface, USB and field bus (option).

Result signals

The device delivers several result signals:

- Accept
- Rework
- Reject and gross leak (gross leak message)
- Envelope curve, filling NOK. (optional)
- Fault

The result signals can vary depending on device variant or have different designations.

Fill pressure, underfill pressure, underfill time and test pressure, are separately set/disabled for each test program.

Times for filling, stabilisation, pause, tare, measurement and venting can be adjusted separately from 0.1 to 999 seconds for each test program.

Measuring range

Δp 0 ...3000 Pa

Resolution 1 Pa; limit contact setting up to max. 3000 Pa
(100 Pa = 1 mbar = 10 mmWC).

Measuring value display

The measurement unit can be switched to:
Pascal, mbar, psi, mmWC, mmHg, ml/min

Design and working principle

The test device is microprocessor controlled, of modular design and, due to its division into pneumatic and electronic sections, can be adapted to the most different requirements of customers. The design as a 19-inch plug-in unit (3HE) enables problem free integration into control cabinets.

The device dimensions for a standard housing in W x H x T are 357 x 142 x 420 mm.

Pneumatics

The pneumatic section of the tester consists of the following main components:

- the pressure control for filling and testing pressure via electronic pressure setting (set up specification by computer) with pressure monitoring by means of an adjustable tolerance range
- a pneumatically controlled isolating valve, which rules out heating of the valve
- a temperature-compensating measuring converter for differential pressure
- a high single-side overload protection (max. 1.4 bar/g) of the differential pressure measuring transducer
- pressure sensors for function monitoring of the pneumatic circuit

See also Pneumatic Diagram in the appendix

Electronics

The electronics section of the tester consists of

- microprocessor system
- a touch display with a resolution of 800 x 480 pixels
- an integrated on/off switch
- key switch to protect against unauthorised changing of test parameters

Scope of delivery

- 1 Leak Tester 3925-0075
- 1 Power cable
- 1 Counter plug to machine control
- 2 Keys for write protection switch
- 1 Operating Manual (USD stick)
- 2 Closing caps
(for specimen connection and reference volume connection)
- Should one of these items be missing or damaged, you should immediately consult your supplier.

Accessories

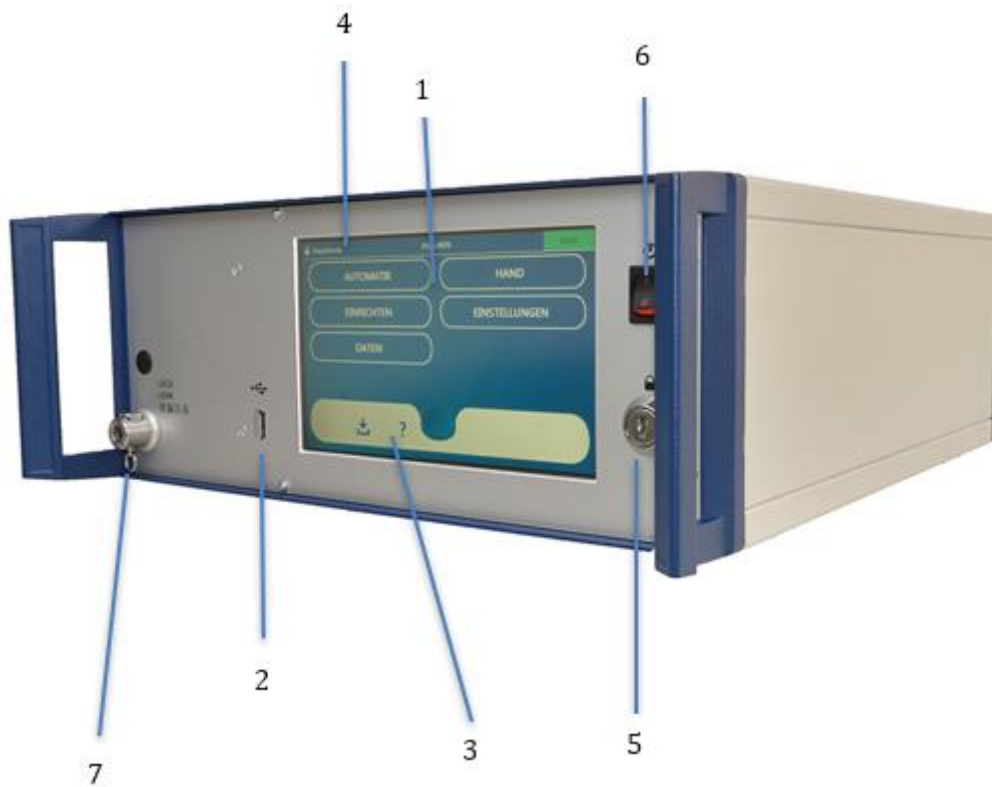

Figure 3: Device view, front

View of device

Front view

1. Touch Display
to display the program menus
2. USB interface
3. Command bar
4. Title - or status bar
to display the user levels, USB interface, fieldbus
5. Write protection switch
to protect against undesired changing of test parameters
6. On/Off switch
7. Stäubli coupling (optional) to connect a test leak

Rear view

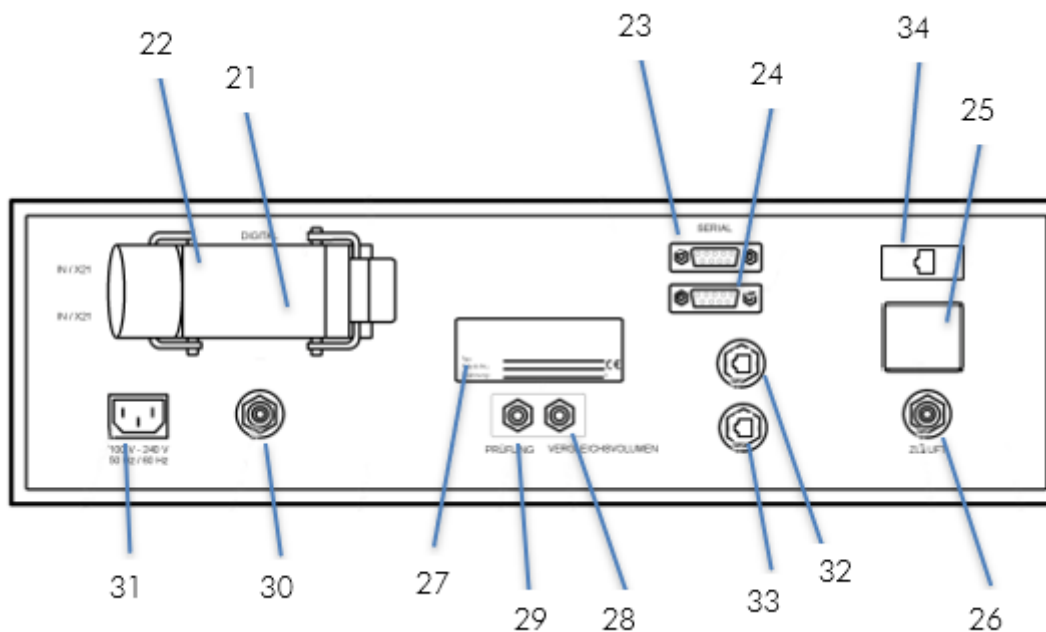

Figure 4: Device view, rear

21. 37-pin Sub-D socket, digital OUT, X20
22. 37-pin Sub-D plug, digital IN, X21
23. 9-pin Sub-D socket, serial, V24 RS232C Ser#1, X22
24. 9-pole, Sub-D jack, Profibus Ser#2, X23 (optional)
25. Table with pressure values for supply air and test media
26. Supply air connection, maximum 10 barg, oil free and filtered
27. Type plate
28. Connection for reference volume (pressure proof original specimen)
29. Connection for specimen
30. Air relief outlet for silencer
31. Cold device socket for power connection 100...240 V, 50.. 60 z. with fuse T 2.0 A
32. RJ45 jack, Profinet 1 (optional)
33. RJ45 jack, Profinet 2 (optional)
34. RJ45 jack, connection for VNC

Installation and start-up

The installation measures described in this manual must only be carried out by trained specialists. The applicable regulations for electrical engineering must in any case be observed and complied with.

Preparations



ATTENTION!

Choose an installation location, at which the device is neither exposed to extreme temperatures, nor to humidity. The ambient temperature must be in the range from 0 to 50 °C, the relative humidity must not exceed 90 % and no condensation should occur.

The device must stand in a firm position, protected against vibration.

Avoid a location near heating or air conditioning systems.

Make sure that the supply voltage matches the supply voltage specified on the type plate.

Only install the device inside a control cabinet if adequate ventilation is assured.

Position the device as close as possible to the specimen, in order to maintain the test circuit volume at a low level and to achieve more accurate measuring results.

Keep a space of approx. 100 mm behind the back of the unit for electric cables, pneumatic hoses and connecting plugs.

Connecting peripheral equipment

Before you can start up the tester, the following connections must first be made: to the compressed air supply, optionally to the test medium, to specimen and reference volume, to the machine control, to the data output through a serial interface and to the power supply. Only then is the leak tester ready for operation.



DANGER caused by electric current!

Separate the device from the electric power supply before connecting device components.

Before connecting compressed air/test medium

In case of major pressure fluctuations in the compressed air supply network we recommend the installation of a pressure switch, which will emit an electrical output signal when the pressure drops. This signal can be used for display/machine shut-down purposes.

Compressed air quality

Cleanliness class of compressed air quality, ISO 8573-1:2010 [3:3:3].

Install a filter unit (min 1µm) in the supply line at a safe and well visible location, to ensure the supply of dry, oil free compressed air. Check the service unit at regular intervals to prevent the device from being soiled by oil. Include the inspection and changing of filter cartridges in the maintenance plan; this applies also for filters with automatic condensate drainage.

NOTE!



Warranty claims will not be accepted if the tester is damaged by oil and/or water entering into the unit.

Connecting compressed air

The supply air connection, for supplying the leak tester with compressed air, is located on the back of the device. The supply air connection has a G¹/₄" fitting for a 8/6 mm hose.

The supplied compressed air must be oil free and filtered. Please make sure that the compressed air to be connected has a constant pressure of approx. 1.5 bar above the filling or testing pressure (min. 5.0 barg, max. 10 barg, see also pressure table on back of housing).

Before connecting the air supply make sure, that the compressed air hose is undamaged and will not be kinked or squashed. The hose must be not pressurised.

After connecting the hose, tighten the spigot nut of the fitting and check for tight fit. Tighten the spigot nut hand-tight and do not use any tools.

Connecting specimen and reference volume

Two fittings G¹/₈" for 8/6 mm hoses for connection of a specimen and a reference volume are arranged on the back of the tester. The dimensions of the hose connections may vary in dependence on the version of the device (test volume).

In order to prevent any expansion (breathing), the hose should be of appropriate strength. A suitable hose (PA-tube) is available from us.

Hose 4/2 mm, max. 45 bar at 20 degrees C, item No. 8082-0354

Hose 6/4 mm, max. 27 bar at 20 degrees C, item No. 8082-0379

Hose 8/6 mm, max. 19 bar at 20 degrees C, item No. 8082-0381

Hose 10/8 mm, max. 15 bar at 20 degrees C, item No. 8082-0382

Make sure that the supply lines to specimen and reference volume are pressure Accept. The lines must be as short as possible. Avoid the use of plug-type fittings because these could cause leakages in the testing circuit.

If possible, use a pressure Accept original specimen as reference volume. With a test volume < 5 000 ml the connection of a reference volume is not necessary. For thin-walled or elastic specimen the connection of a reference volume may be necessary, even for small volumes. If you do not connect a reference volume, you must close the reference volume connection with the blind cap provided for this purpose.

Before connecting the reference volume make sure that the hoses for test medium and reference volume are undamaged and will not be kinked or squashed. The hoses should not be pressurised.

NOTE!

If you do not connect a reference volume, you must close the reference volume connection with the blind cap provided for this purpose.

After connecting the hose to the specimen connection, Accepten the spigot nut of the fitting and check for Accept fit. After connecting the hose, Accepten the spigot nut of the fitting and check for Accept fit. Accepten the spigot nut hand-Accept and do not use any tools.

If necessary plug the hose to the reference volume connection (19), Accepten the spigot nut of the fitting and check for Accept fit. Accepten the spigot nut hand-Accept and do not use any tools.

Connecting the machine control

There are several possibilities for communication between tester and machine control:

Parallel interface

the 37-pin Sub-D socket, digital OUT,
X20 (position number 21, on back), for output signals

the 37-pin Sub-D socket, digital IN,
X21 (position number 22, on back), for input signals

- Wire the plugs first according to the *plug assignment diagram* in the *appendix*.
- Provide a suppressor circuit (e.g. varistor or diode) for all output signals, in order to avoid interferences.

The tester requires a pulse of at least 1 second. The outputs need approx. 5 mA, the outputs can be loaded with max. 0.5 A (max. 30 VDC).

Once all preparations have been made:

- Connect all plugs and ensure Accept fit.

The modes of input and output signals can be found in the enclosed flow chart.

Connecting serial interface(s)

After completing the test, the up-to-dated measuring values can be output to a data terminal unit via the serial interfaces. The Appendix to these instructions contains a few sample printouts. The header appears on each new page.

The test parameters for the existing programs can be output in the menu **SET UP TEST PROGRAMS** (Test program output (test programs))

The two serial interfaces of the device are:

- 9-pin Sub-D socket, serial, V24 RS232C Ser#1, X22
(position number 23 rear)
- 9-pole, sub-D jack, serial RS232 Profibus Ser#2, X23
(position number 24, rear)
(optional)

Wire the plug connections by following the enclosed plug assignment diagram.

Transfer format: (factory setting)

115.200 baud, baud rate adjustable from 300 ... 921 600,
8 bit data, 1 stop bit, no parity bit, no handshake

Connecting the electric power supply

Connect the leak tester only to a main voltage of 100 ... 240 V, 50/60 Hz (without changeover) provided for this purpose.

The power consumption of the device is approx. 100 VA.

It is protected by a T2A / 250V IEC127-2 input fuse.

Power cable plug with power connection (31)

Connect the power supply cable to the mains supply network.

The tester is ready and can be switched ON.

Initialise

Booting process

Before starting operation all connections to peripheral equipment must be made and checked for Accept fit.



- Switch on all peripheral equipment by following the corresponding instructions.
- Switch on the tester, see previous section.
The display is switched on and the device is initialised.



Figure 5: Start screen



Figure 6: Main menu with the fieldbus symbol in the menu bar

- Test devices with activated Fieldbus interface try to make a connection to the Fieldbus during the initialisation. If the connection to the fieldbus is successful the symbol appears in green. 
- If a connection cannot be made to the fieldbus then the logo remains yellow. 

The touch display

The leak tester is equipped with a resistive touch display. It can be operated with the finger or with a suitable stylus.

If too much force is applied to the touch display, the touch display may be damaged and may even break.

Do not apply too much pressure to the touch display and do not use any pointed objects, such as a mechanical pencil, when operating it.

NOTE!
 Damage caused by operation with strong pressure or a pointed object will void the warranty.

- Wait until the initialisation has been completed and the **Main menu** appears in the display.

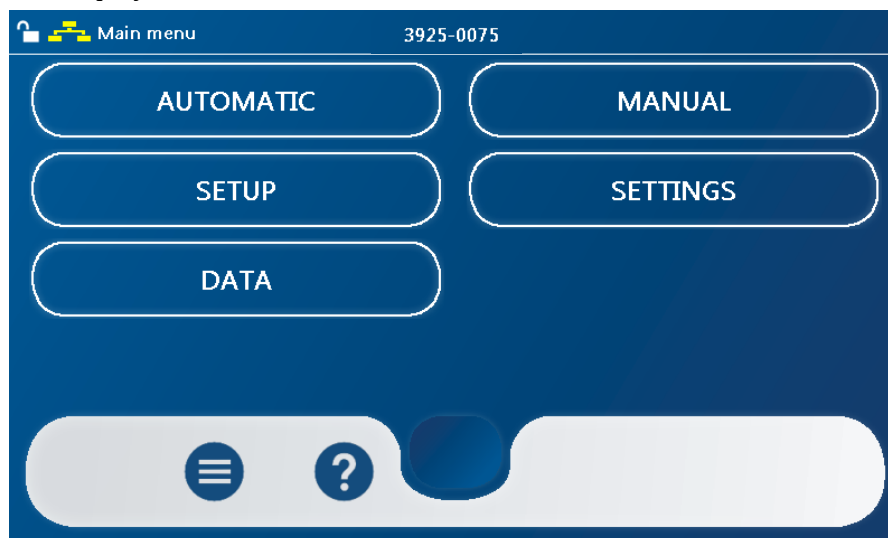



Figure 7: Main menu after initialisation

Title or menu bar

The name of the current dialog window or application always appears in the top left-hand corner of the display. The user level is displayed at the top left.

	User 2:	Operator
	User 4:	Setter

User level 2 is the standard setting. The keyswitch can be used to activate user level 4.

Main window

In the main menu you will find the individual selectable sub-menus.

Command bar

The command bar shows the available keys to operate the current menu:



- Help



- Context menu

Working with the program

The device is interactively operated by means of a menu system, which always ends in a dialog window. The name of the current dialog window appears in the header or menu bar at the top left in the dialog window. The keys, which can be used for operation, are listed in the command bar at the bottom.

You can select a menu point by pressing a button.

Using the write protection switch

The possible input in a dialog window depends on the position of the write protection switch on the tester. If the key switch is in vertical position or is pulled off, the device is in write protected viewing mode and you can only make a few changes concerning the selection and appearance of saved data.

When you turn the key to the right, you switch on the input mode, and you can change saved data or enter new data.

You can always close a dialog window by pressing the keys



and/or



If you leave a dialog window with this button



then changed values will not be

saved. If the keyswitch is turned from the horizontal to a vertical position then changed values are saved.

If you leave a dialog window with the button



you will be asked whether

whether the changes made are to be saved.

Command reference

In this chapter you will find all commands and functions of the control software for the leak tester Leak Test 3925-0075. The sequence follows the program structure, as shown in the table. The display of the menu points depends on the user level, here user level 4.

Overview of menu levels

Level 1	Level 2	Level 3	Level 4
Main menu	Automatic		
	Manual	Test	
		Flooding	
	Setup	Test programs	
		Sequencer	
		Interfaces	Serial #1
			Fieldbus (optional) Profinet or Profibus
			TCP/IP
			USB-Stick
	Settings	System status	
		System parameters	
		Software version	
		Options	
		Display	
		Date and time	
		Software update	
		Stabilise pressure system	
	Data	View program status	
		Data collection	
		Operating data	
		Data export	
		Data import	

After you have started the device and the initialisation process is completed, the display will show the **MAIN MENU** of the program or, if applicable, the previously set start menu.

AUTOMATIC menu

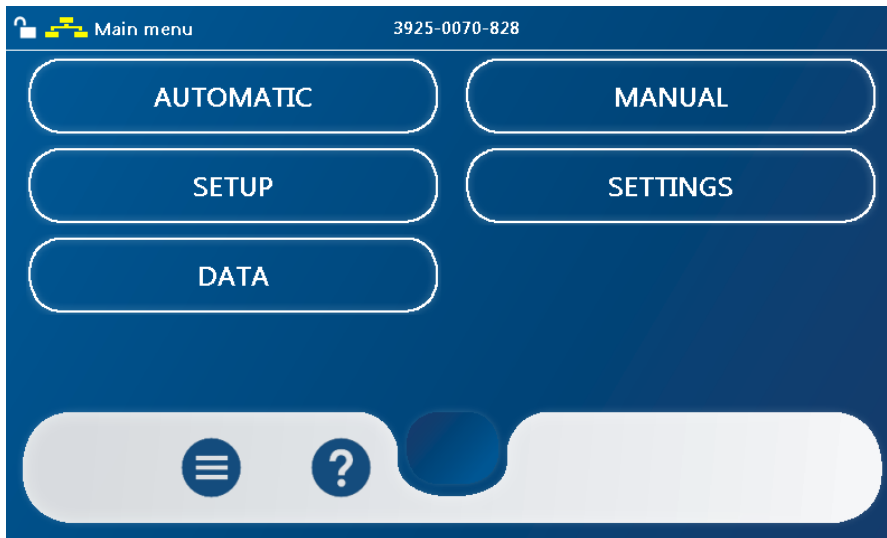

Figure 8: Dialog window main menu

In **AUTOMATIC** mode the device is entirely controlled via the interface for machine control. This menu can only be used to monitor the sequence.

On the touch display, push on the Automatic menu point

- The display shows the sub-menu **AUTOMATIC**.

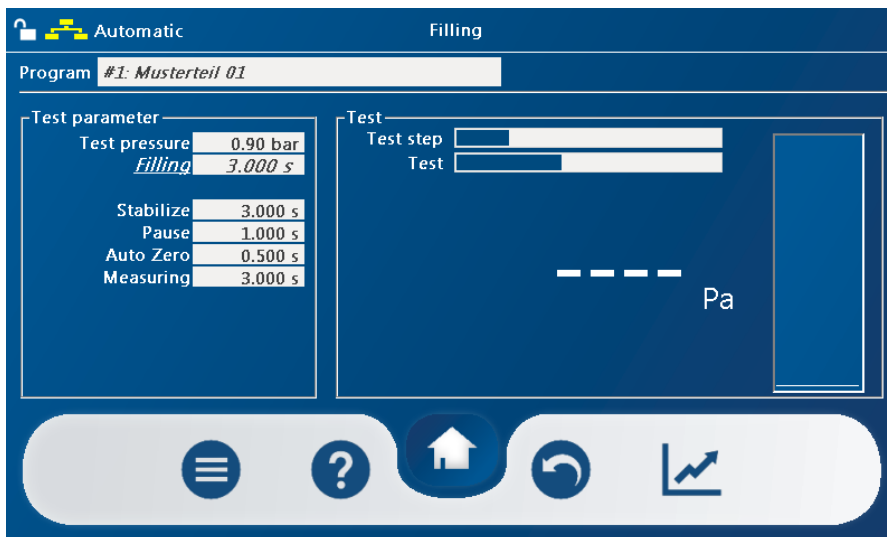

Figure 9: Dialog window Automatic

Pressing on the button  "Graph" changes to the filling curve view

Filling curve display

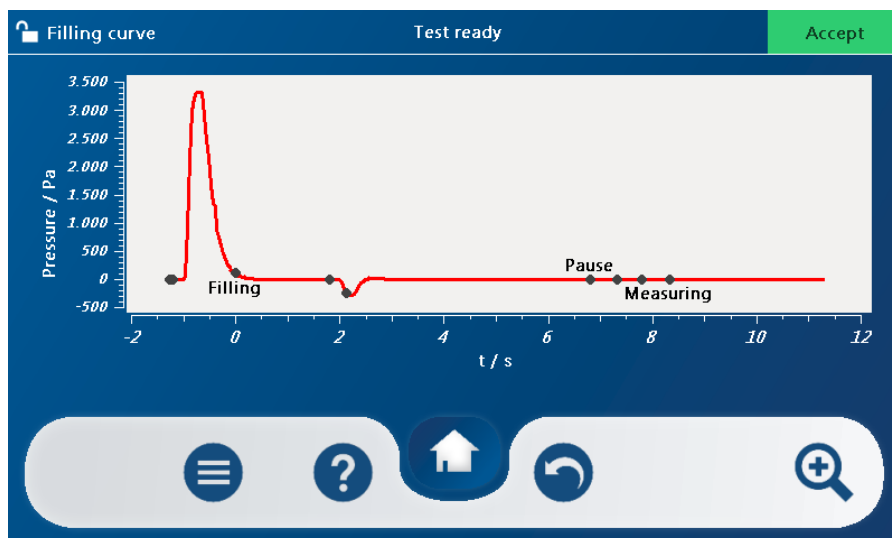



Figure 10: Dialog window filling curve view

The  "Return" button returns you to the previous window.

Sequencer

The sequencer function can be globally activated or deactivated.
(see sequencer setup)

With the sequencer activated, the transmitted program number is interpreted as **Sequencer Number**. The transmitted program number must only be in the range from 1 to 10. Otherwise an error message 3 (**Program not available**) will be submitted.

With the **Start** signal the steps memorised under the selected sequencer number are successively processed.

In the automatic dialog window, the sequence number **Sequencer --** and the active step **Step --** are displayed next to the program number.

With the sequencer activated the number of passed cycles and the total number of cycles are displayed in between the measuring result and the measuring value unit.

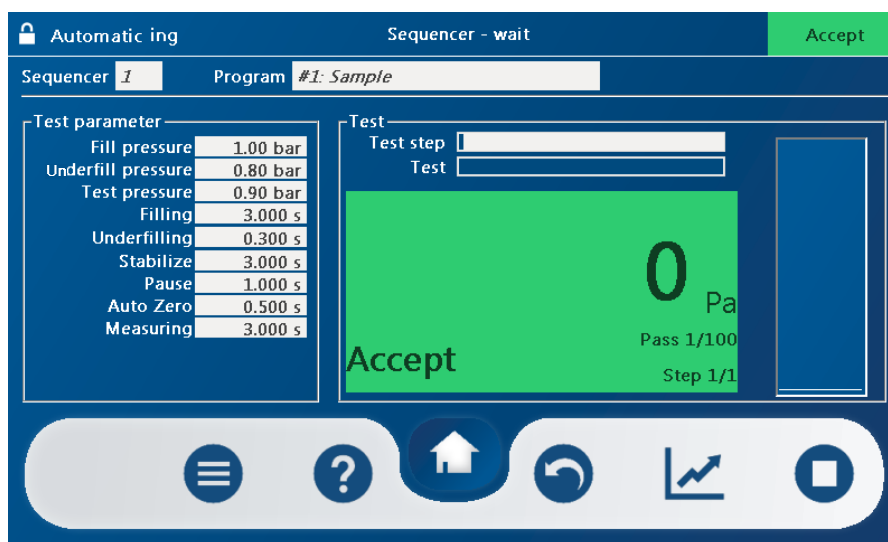

Figure 11: Dialog window Automatic step

If an error occurs in the sequence, the output error will be set and the complete test sequence aborted. The error must be acknowledged as specified for the corresponding machine interface. After a restart the complete test sequence is repeated.

If the input **Abort** is set, the entire test sequence will also be aborted. A restart will thus also start with the first activated test step.

In dependence on the setting of the switch **NOK=continue** for the corresponding test step, the sequence is aborted or continued in case of a measuring result unequal **Accept**.

At the end of any test step the output of the corresponding test result is set for a short time.

If none of the 10 possible steps is activated in the selected sequencer, the error message **no step activated** with error number 40 will be generated.

Automatic mode without leak simulation

In automatic mode the device is operated through a machine control interface. For more details please refer to chapter *Exchange of signals with the machine control*.

Automatic mode static test (flooding)

If the signal Static Test X21/4 is applied instead of the signal Start X21/2, the specimen will be exposed to the test pressure determined in the parameter set of the selected program. The specimen is kept pressurised, as long as the signal Static Test is applied.

MANUAL menu

The **MANUAL** menu is used for manual operation of the test device. You can enter all commands manually via the touch display (input can also be by keyboard and / or mouse connected to the front USB connection).

If you select the **MAIN MENU Manual** , then the **MANUAL MENU** is displayed. There are two sub-menus available:



Figure 12: Dialog window Main menu - Manual

- Test.
You can check manually with and without leak.
- Pressurise (flooding).
You can pressurise the specimen manually with test pressure.

Test

If you select **Test** by pressing the button on the touch display, an empty dialog window **MANUAL** appears.

To launch the desired program:

- tap on the empty field next to "Program" and select the desired program from the list, and confirm the selection by pressing the "OK" button

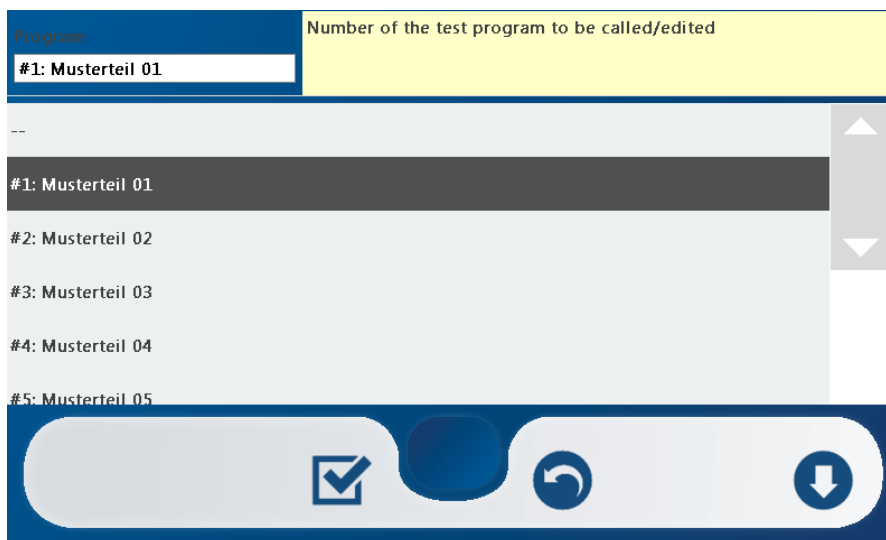

Figure 13: Dialog window Manual - Program selection

- ☑ Confirm with the "OK" key. The program is loaded into the memory.

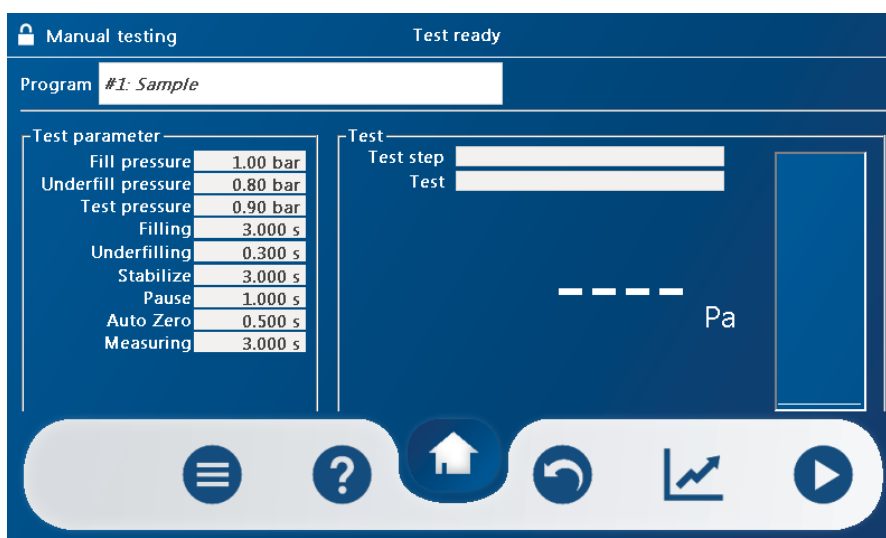



Figure 14: Dialog window Manual - Test

Test without leak simulation

The dialog window **MANUAL** gives you the possibility to start a test without leak simulation.

 Press "Play" key to start the test without leak simulation.

NOTE!



If, in the **SET UP TEST PROGRAM**, the option **Analyse envelope curve activated** has been activated, then after the test sequence of the first test, the error message **REFERENCE CURVE MISSING** appears.

For the initial testing of the device functions, you should temporarily disable this option. The reference curve determination function is described later.

The test sequence can be easily followed by the horizontal progress bar. The current status of the test sequence is additionally displayed in the help bar.

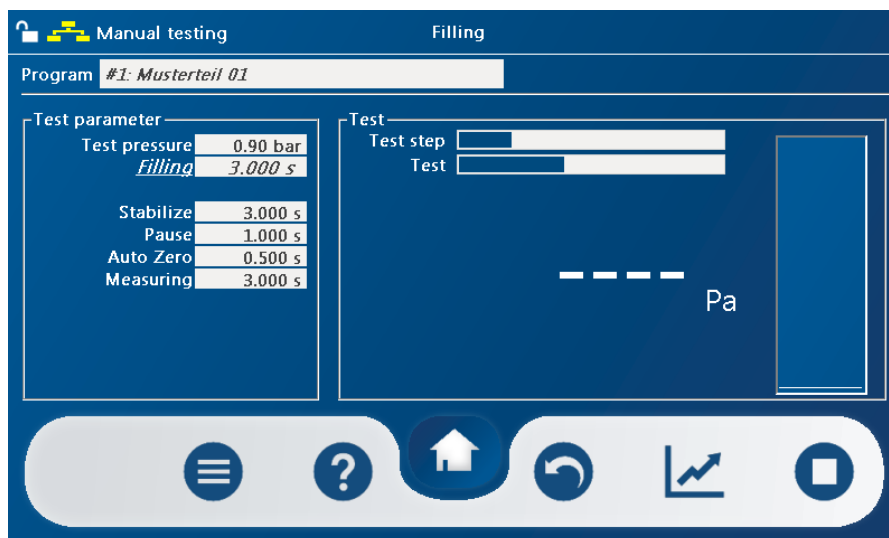

Figure 15: Dialog window Manual testing

Test with leak simulation

Before starting the test, connect the test leak (optional) An overview of the available options and the function of the leak simulation can be found here, [Leak simulation](#)

The dialog window **MANUAL** gives you the possibility to start a test with leak simulation (optional).

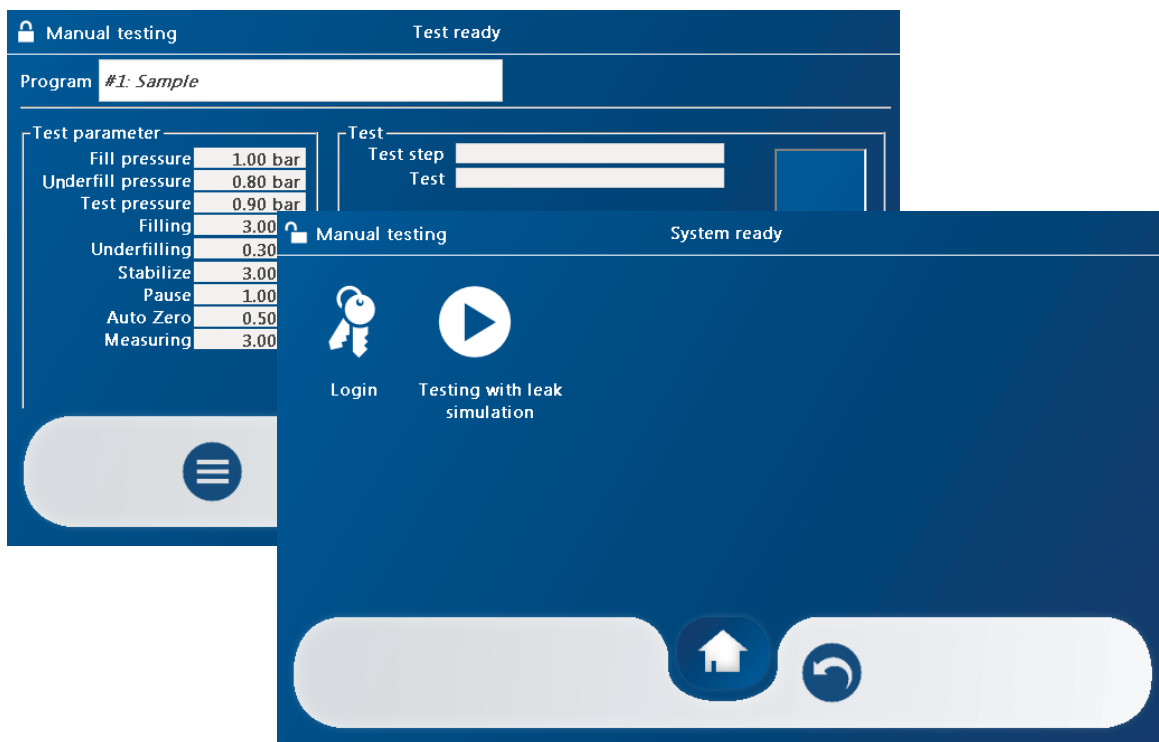



Figure 16: Dialog window Manual Testing with Leak

- Call up by pressing  the context menu
- Start the test with leak simulation by pressing 

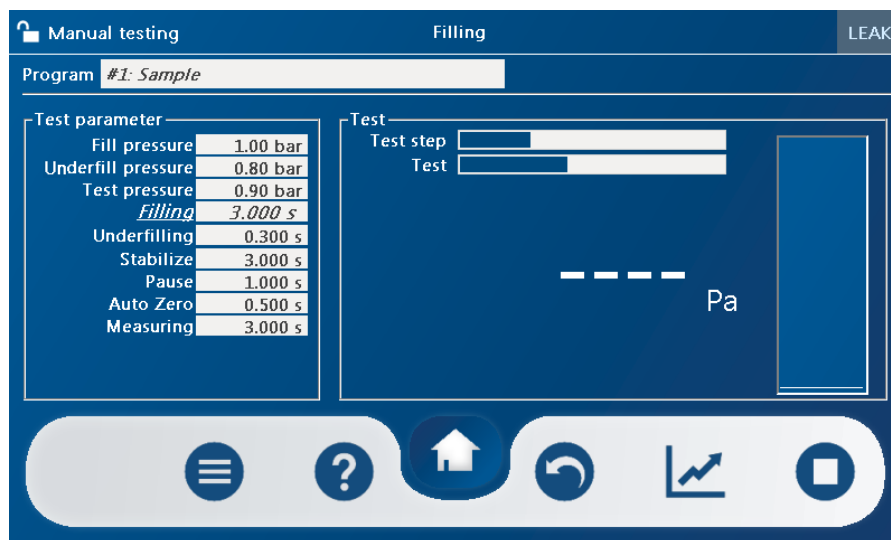

Figure 17: Dialog window Manual testing with activated leak simulation

- The activated leak simulation can be detected by the flashing "Leak" at the top right corner

If you prefer the filling curve display:

- With a push on the button  change to the filling curve view

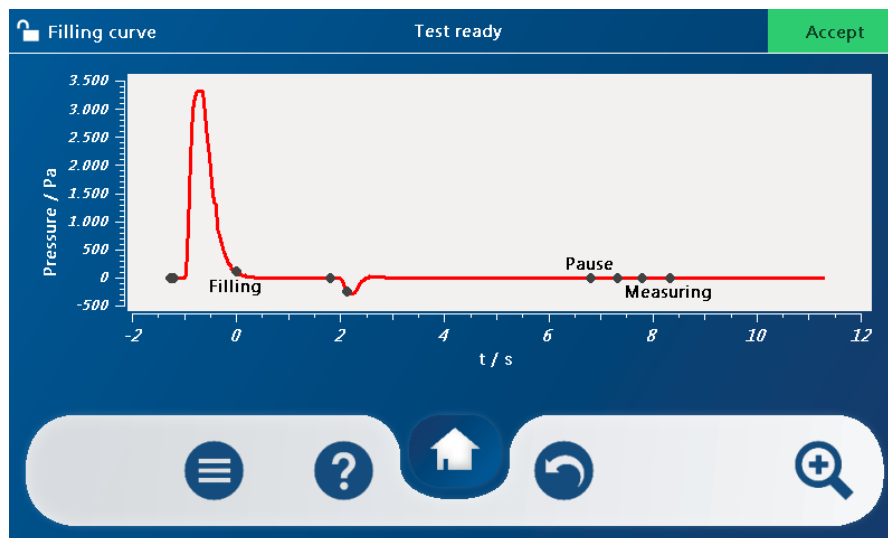



Figure 18: Dialog window Manual testing - Filling curve

The  "Return" button returns you to the previous window.

You can now push on the "Home" button



to jump to the main menu and call up and execute other functions in the device, without interrupting the testing process. The test sequence is not interrupted but continues in the background. The test result is displayed after the test sequence has finished.

To interrupt the test, push on the "Stop" button  in the Test sequence dialog window

- The test sequence is aborted, the up-to-date status of the test at the time of the abortion remains in the display.

Determination of a reference record

Connect a leak free original work piece to the tester.

Proceed as follows to determine the reference curve:

Enter the number of the desired program (in the example, 1) in the top row

 Push the "OK" button.

 Press "Play" key to start the test without leak simulation

You can follow the test sequence with help of the cursive letters of the test parameters and with the horizontal progress bar, the status bar additionally shows the corresponding actual test step of the test sequence.

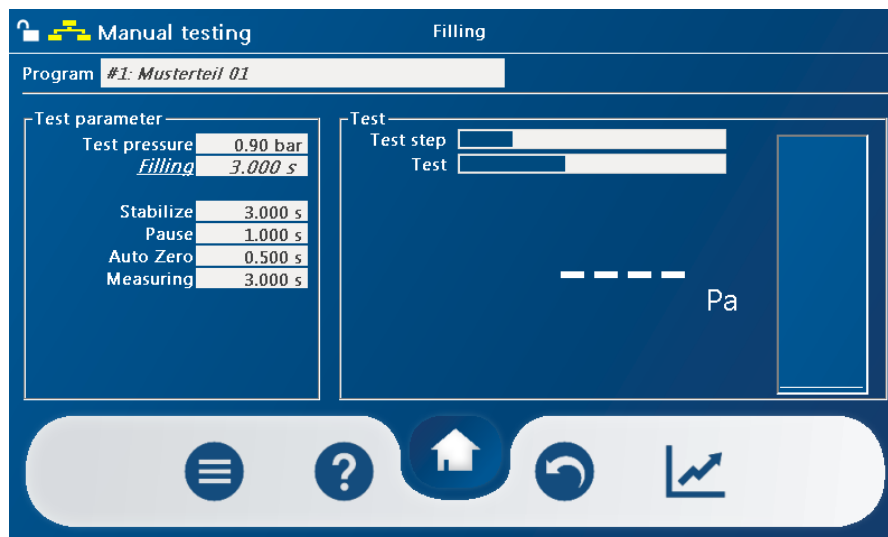

Figure 19: Dialog window Manual test sequence

Once the test is completed, the display will show the following error message.

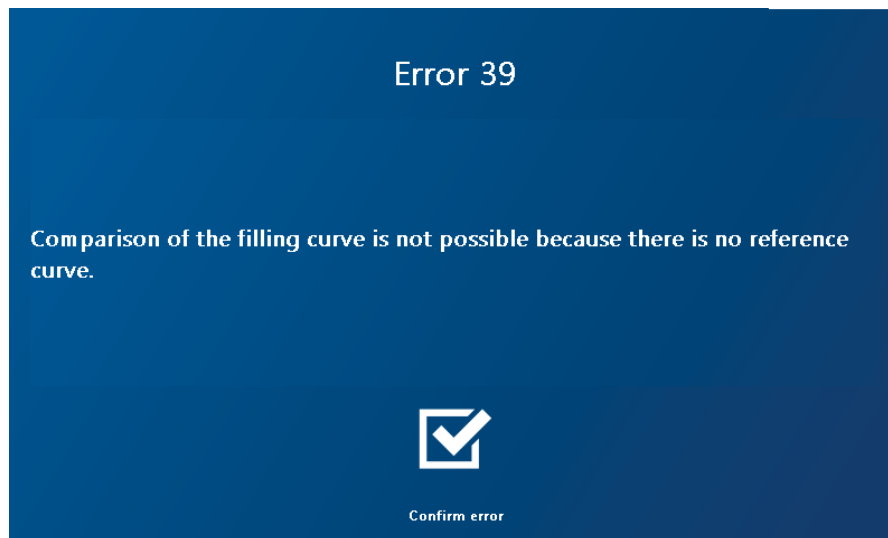

Figure 20: Dialog window Error 39

- Acknowledge error with a push on the "OK" button

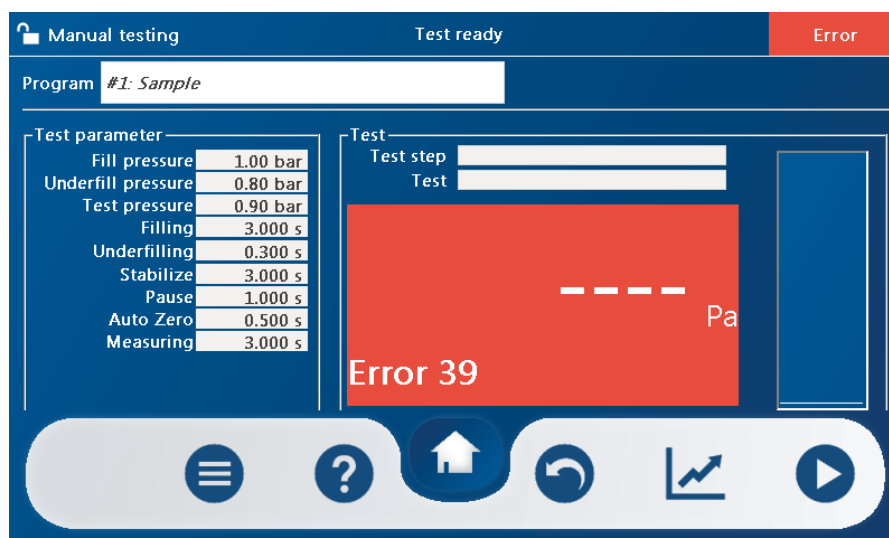

Figure 21: Dialog window Error 39 acknowledged

- Pressing on the "Graph" button,



changes to the filling curve view



Figure 22: Dialog window Save reference curve



Push the "Context menu" button



Push the "Save" button to save the reference curve

- To determine a new reference curve - do the measurement again and overwrite the existing curve

Sequencer

The sequencer is available in automatic mode and in manual mode.

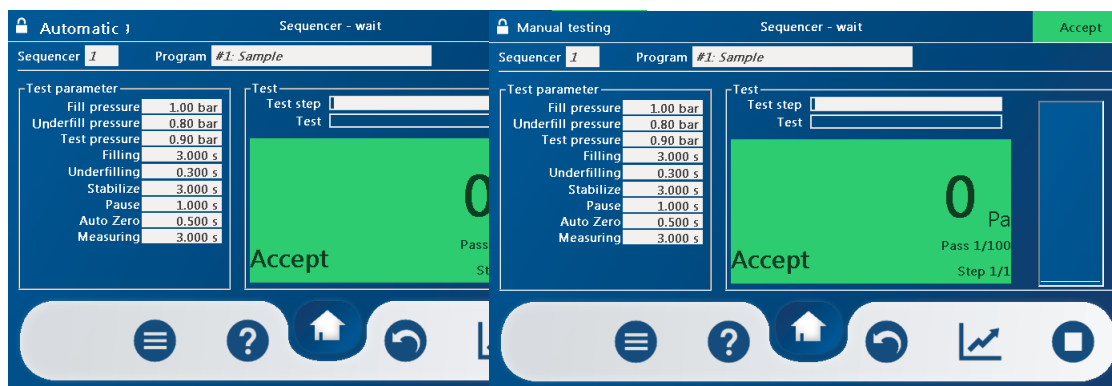

Figure 23: Dialog window - Sequencer Automatic/Manual

The number of the sequencer is always visible. A combined presentation of sequence number and program number is displayed.

In the measurement window, the current flow and the step number is shown.

Working principle:

Sequencer disabled:

- Sequence number is deactivated

Automatic mode:

The input fields **Sequencer:** -- and **Program:** -- cannot be edited.

Operation mode manual:

The field **Sequencer:** -- cannot be edited. The field **Program:** -- is editable, as long as no test cycle was launched. The input range is with 1 ... 99 indicated.

If the entry is closed with  if available, the corresponding

test program is loaded, and its test parameters are displayed.

Afterwards, the test sequence can be started with 

Sequencer enabled:

In the field **Sequencer:** -- the sequence number is displayed. The field **Program:** -- cannot be edited.

Automatic mode:

The fields **Sequencer:** -- and **Program:** -- cannot be edited.

If the sequencer program is not available or if no test program is activated in the sequencer program, the input is not accepted, and the respective error messages appear.

If an error occurs in the sequence, the output error will be set, and the complete test sequence will be aborted. The error must be acknowledged as specified for the corresponding machine interface. After a restart the complete test sequence is repeated.

If the input **Abort** is set, the entire test sequence will also be aborted. A restart will thus also start with the first activated test step.

In dependence on the setting of the switch **NOK=continue** for the corresponding test step, the sequence is aborted or continued in case of a measuring result unequal **Accept**.

At the end of any test step the output of the corresponding test result is set for a short time.

If none of the 10 possible steps is activated in the selected sequencer, the error message **no step activated** with error number 40 will be generated.

Flooding

Figure 24: Dialog window, Manual flooding

- Enter the program number into the input field and confirm with a push on the button. 
- The dialog window with the chosen program is displayed. You can track the set-up of the programmed test pressure by following the "Pressure in system" display.

Flooding without leak simulation.

The dialog window **MANUAL PRESSURISE** gives you the possibility to pressurise the test specimen without leak simulation.



- Press key  to start pressurise without leak simulation.



Figure 25: Dialog window Manual flooding - Ready for flooding

- When button  appears, flooding can be started by pressing the button.

The status of the pressure build-up can be tracked by following the "Pressure in system" display. In the menu bar, the corresponding current flooding status is shown.

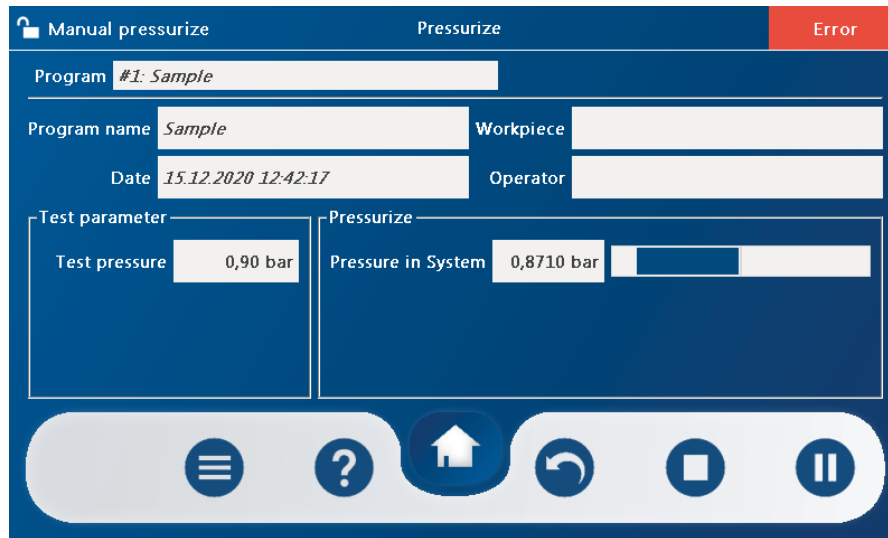



Figure 26: Dialog window, Manual flooding - Flooding

- Flooding can be aborted by pressing the  "Stop" button.
- Flooding can be paused by pressing the  "Pause" button

NOTE!



In the operation modes for automatic and semi-automatic testing, the duration of pressurising is determined by application of the signal PRESSURISE ON.

SET UP menu

In the **MAIN MENU**, under **SET UP**, you will find the dialog window **SET UP**. This menu can be used to set up test programs, set the sequencer to set up the various interfaces.

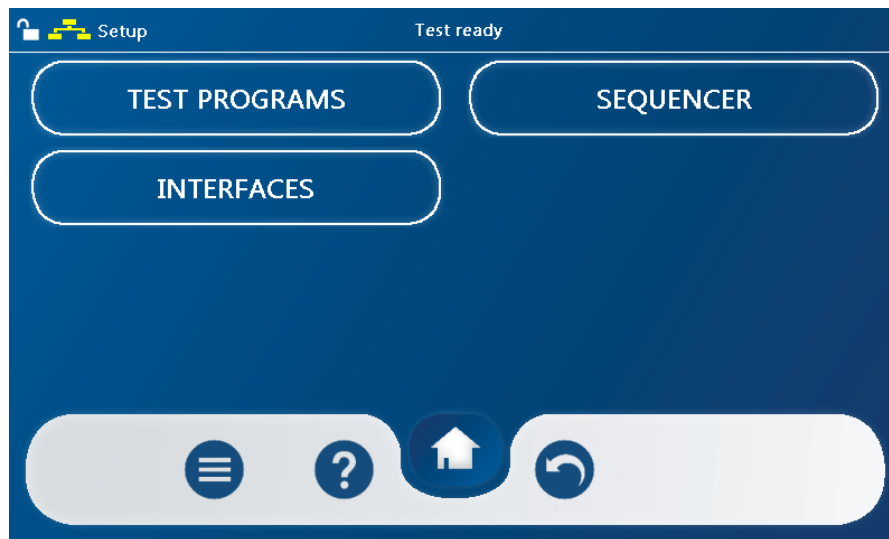

Figure 27: Dialog window Setup

Test programs

If, in the dialog window **SET UP**, the **Test program** is selected by pressing the button, the following dialog window opens:

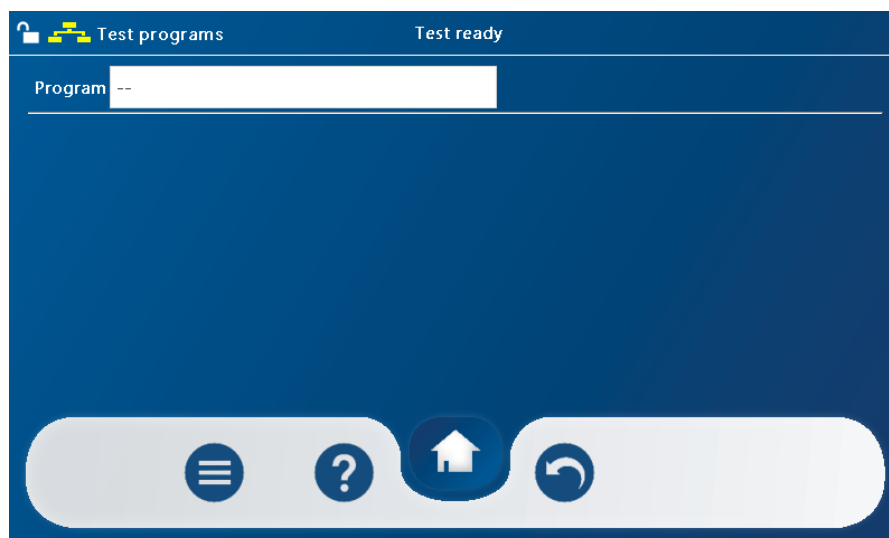





Figure 28: Dialog window Set up - Test program

Creating or changing a test program

In order to be able to make entries in this dialog window, you must first switch the device to edit mode with the key switch:

- Turn key switch clockwise. Write protection is disabled, entries can be made
- This is recognisable by the  opened padlock at the upper left of the menu bar
- Make all required entries and confirm by pressing 

NOTE!

If you would like to create a new program, enter an unassigned program number, and confirm your selection by pressing the "OK" button. 



If you would like to change a previously assigned program, enter the corresponding number, and confirm its selection with the "OK" button 

NOTE!

Using the  "Up" and  "Down" buttons you can navigate through the program.



NOTE!

You can leave the menu without changed values by pressing 



Program

Enter a number between 1 ... 99.

Program name

Maximum 23 characters (elective)

Work piece

Maximum 23 characters (elective)

Operator

Maximum 23 characters (elective)

Use the filling pressure

"Use filling pressure" can be activated/deactivated by pressing the button on the check box.

Default setting is activated

Use the underfill pressure

The "Use underfill pressure" can be activated/deactivate by pressing the button on the check box.

Default setting is activated



NOTE!

Use fill pressure and **Use underfill pressure** can only be activated/deactivated together.

Use venting

"Use venting" can be activated/deactivated by pressing the button on the check box.

Default setting is deactivated

Vent if NOK

"Vent for NOK" can be activated/deactivated by pressing the button on the check box.

The recommended value is activated when "Use venting" is activate

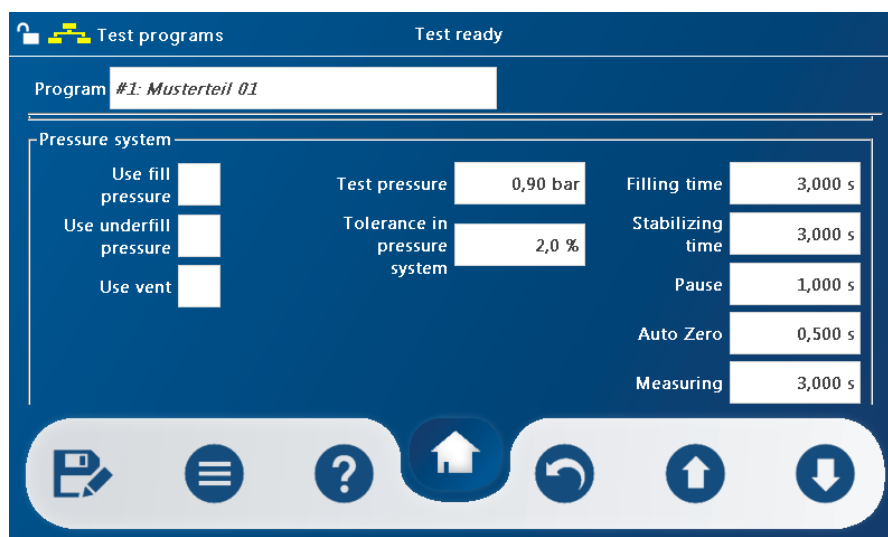

Figure 29: Dialog window Set up test program

Filling pressure

You may enter a value between 0.20 ... 6.00 bar or accept the default value of 2.20 bar.

Underfilling pressure

You can enter a value between 0.20 ... 6.00 bar or accept the default value of 1.80 bar.

NOTE!

Calculate the underfill pressure as in the following example:



Fill pressure $F = 2.10$ barg

Test pressure $P = 1.90$ barg

Underfill pressure = $P - (F - P) = 1.90 - (2.10 - 1.90) = 1.70$ barg

NOTE!

Change the default values for underfill time, pause time and tare time only after consulting the manufacturer.



Underfilling time: 0.3 s, Pause time: 1.0 s and Tare time: 0.5 s.

Set the times so, that an open specimen connection will cause a rapid shut-down.

Test pressure

You may enter a value between 0.20 ... 6.00 bar or accept the default value of 2.00 bar.

Pressure tolerance

The value should be 1.0 ... 10.0% and it is the tolerance of the pressure regulation in % of the end value.

Filling time

Enter the fill time in seconds from 0.10 ... 999.99

Default value is 3.00 sec.

Stabilisation time

Enter the stabilise time in seconds from 0.10 ... 999.99.

Default value is 3.00 sec.

NOTE!

Change the values for underfill time, pause time and tare time only after consulting the manufacturer. Accept the default values for the underfill time: 0.3 s, Pause time: 1.0 s and Tare time: 0.5 s.



In case of low test pressures (approx. <0.5 bar) or low volume specimen (approx. <100 ml) the pause and tare times may need to be shortened (possibly no test pressure in specimen).

The times must be set in such a way, that an open specimen will trigger a rapid shut-down.

Pause

Enter the pause time in seconds from 0.10 ... 999.99.

Default value is 1.00 sec.

Tare

Enter the tare time in seconds from 0.10 ... 999.99.

Default value is 0.50 sec.

Measuring

Enter the measurement time in seconds from 0.10 ... 999.99.

Default value is 3.00 sec.

Venting

Enter the venting time in seconds from 0.10 ... 999.99.

Default value is 1.00 sec.

**NOTE!**

The entered vent time influences the output time for the result message after completing the measurement.

Figure 30: Dialog window Test program set up measurement unit

Measuring value unit

The measurement unit is selected by pressing the input field next to the measurement unit.

Pascal, mbar, psi, mmWC, mmHg or ml/min. Default setting is Pascal.

- Confirm by pressing  or leave the menu by pressing



Volume factor

This value is for the calculation of the conversion of the measuring value to ml/min. The factor must be 0.000001 ... 9.999999.

To display the leak rate in ml/min the leak tester requires a volume multiplier. This volume multiplier can be calculated with the following formula:

$$\text{Volume multiplier} = \frac{\text{known leak rate (ml/min)}}{\text{measured value on measuring value display (Pa)}}$$

NOTE!

The volume factor parameter appears only after the measurement unit "ml/mm" has been selected.

NOTE!

When parameters were changed, the conversion factor must be determined again.

Tare of device

This value influences the zero point of the device. Depending on the direction of the entered value, the zero point is reduced in case of negative values and increased in case of positive values.

Enter the fixture offset from -20 ... 20 Pa.

Default value is 0 Pa.

Series fault from

Here you can specify from which number of test results **REJECT** in direct consecutive a fault is present. Input range is 0...999

Default value is 5.

NOTE!

If you enter a value of 0, the function is switched off.

Use the Rework limit value

The "Use rework limit value" can be activated/deactivated by pressing the button on the check box.

Default setting is activated

Rework limit value

The intervention limit for reworks must be 1 ... 3000 Pa.

Default value is 100

Leak

The intervention limit for leaks must be 1 ... 3000 Pa.

Default value is 200

Analyse envelope curve

The "Analyse envelope curve" can be activated/deactivated by pressing the check box.

Default setting is deactivated

Envelope curve tolerance

The value should be 0.1 ... 100.0 % and it is the tolerance of the permissible deviation from the stored reference curve in % of the end value.

Compare envelope curve from

Enter the enveloping curve start point in seconds from 0.00 ... 999.99.

Default value is 0.00 sec.

The start point of the enveloping curve is the point in time from which the deviation of the enveloping curve from the reference curve is recorded, after the leak test has been started.

Compare envelope curve to



Enter the enveloping curve end point in seconds from 0.10 ... 999.99.

Default value is 3.00 sec.

The end point of the enveloping curve is the point in time at which the evaluation of the enveloping curve's deviation from the reference curve is stopped, after the leak test has been started.

Saving the test program:**NOTE!**

Program parameters can be saved after input of a parameter or

- All parameters by pressing the button  or by
- Rotating the keyswitch to position 
- Turn the key switch anti-clockwise to vertical position. The changed data are saved
- Pull off the write protection switch in vertical position , to avoid undesired changes.

If you would like to leave the menu without saving, push on the  "Return" button, then the following dialog window appears

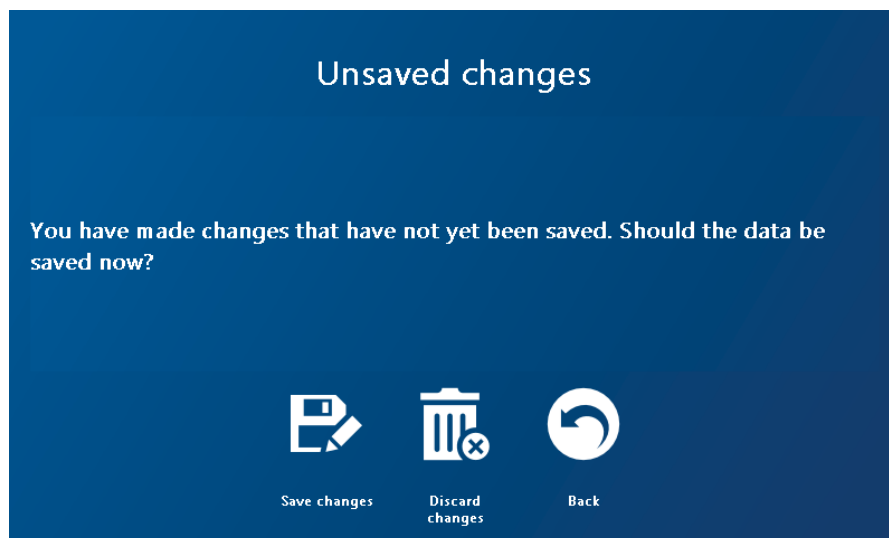





Figure 31: Dialog window Unsaved changes

Here, select  to reject changes, then changes are not accepted and you return to the Set up menu. Now you can return the keyswitch to its former position. Rotate into the write-protected position , so changes are not saved.



Attention!

If you have left the program to be edited via the  "Home" button, then by returning the keyswitch to the write-protected position , all changes are saved, no matter which menu you are in.

Printout test programs (test parameters)

Here you can decide whether the program parameters should be shown on the display or be output to an interface. Additionally you can select which program parameters should be displayed or output.

In the **MAIN MENU**, under **SET UP**, you will find the dialog window **SET UP**.

In the **SET UP** menu under **TEST PROGRAM**, enter the desired test program number. The program parameters will be shown in the display.

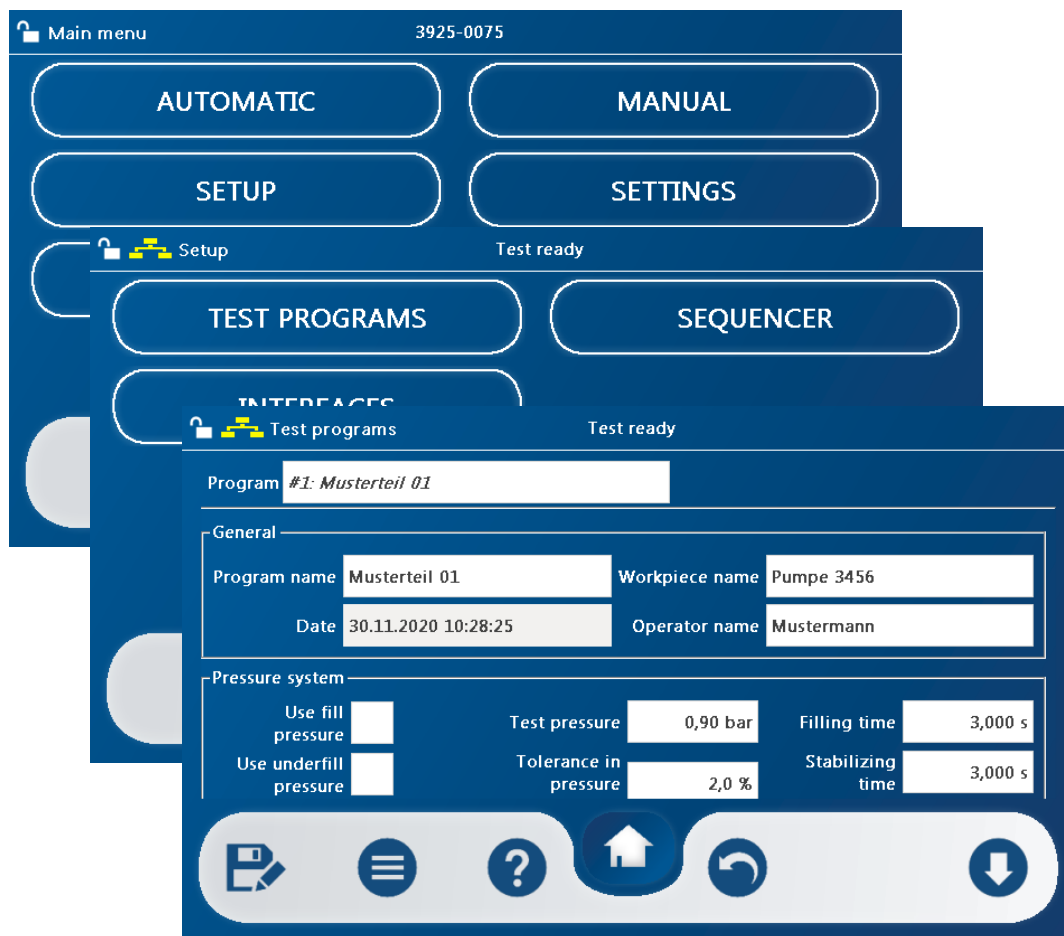

Figure 32: Data output test program

- By pressing the button  the following window opens

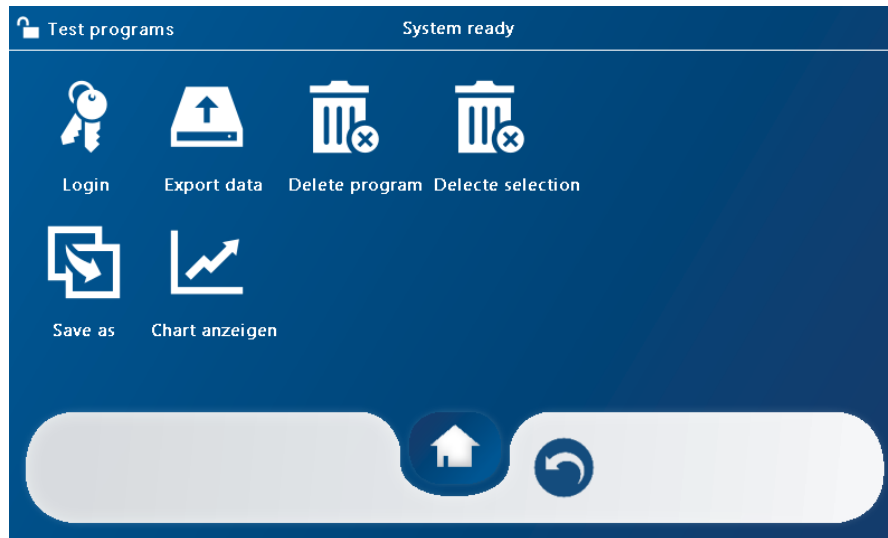

Figure 33: Dialog window Context menu test program

- By pressing the button  the Export window opens

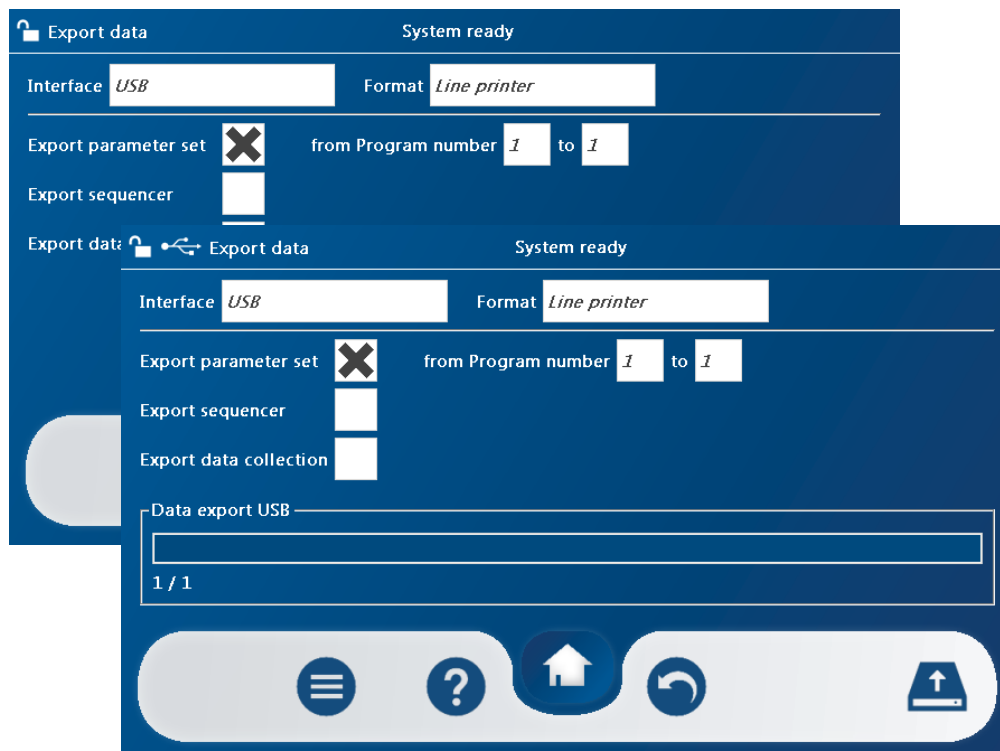



Figure 34: Dialog window Data export test program

- Select the interface to be used in the "Interface" input menu
- Select the output format to be used in the "Format" input menu.

NOTE!

A detailed list of possible interfaces and formats can be found in Appendix [Data output formats](#)

- Select the program number(s) to be exported
- Plug in the USB stick and start data export by pushing 
- Only remove the USB stick after the progress bar has disappeared

NOTE!

With a data output to a USB stick, a file will be automatically generated. The name comprises the following

Line printer: DPG20100200_LPR.txt

DPG: Leak Tester

20100200: Serial number of the device

LPR: Line printer format

txt: Text file



If a file with same file name already exists, the file will be opened and the data append to the file.

Copying an existing test program

If you would like to copy an existing test program, you must save it under a different program number.

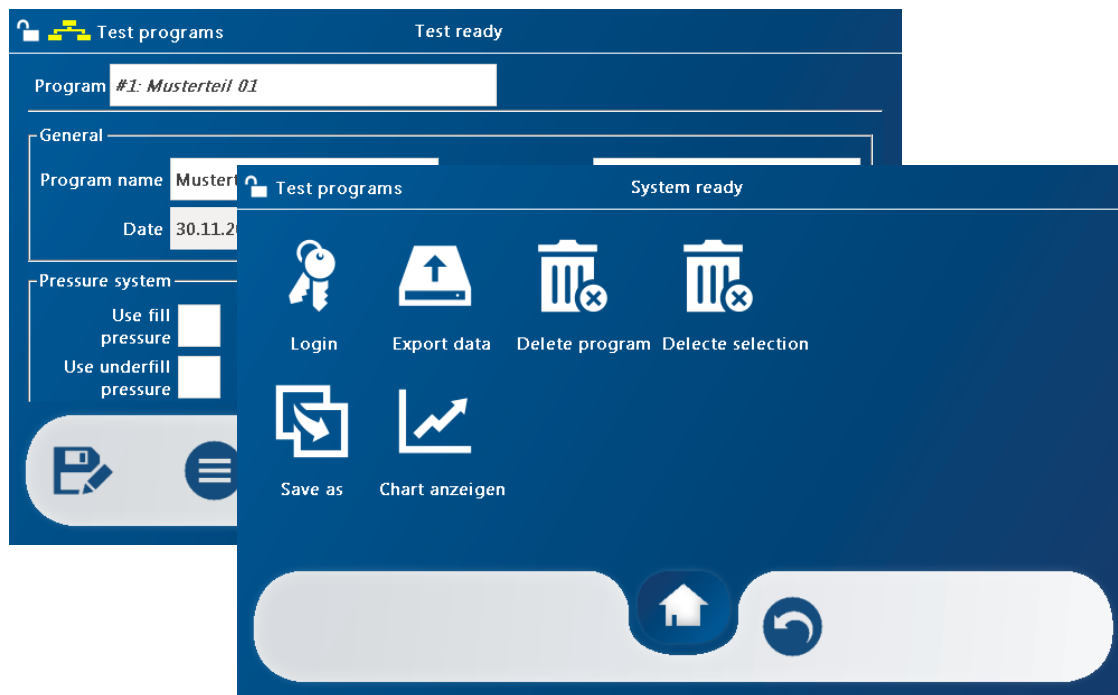



Figure 35: Dialog window Copy test program

- Call up existing test program in the "Program" dialog
- Call up the context menu by pressing the button 

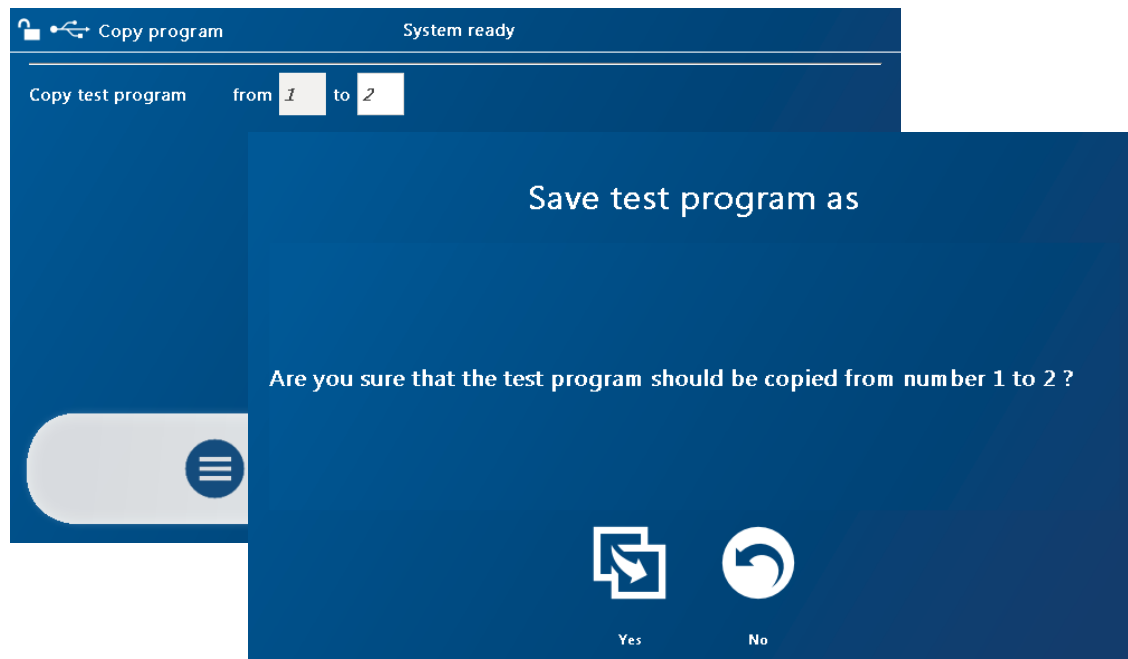

Figure 36: Dialog window Save test program as

- Select the program space for the program to be copied and confirm with "Yes". The program has been copied.

Sequencer

In the dialog window **SETUP SEQUENCER** you can set up or change a testing sequence with max. 10 test steps.

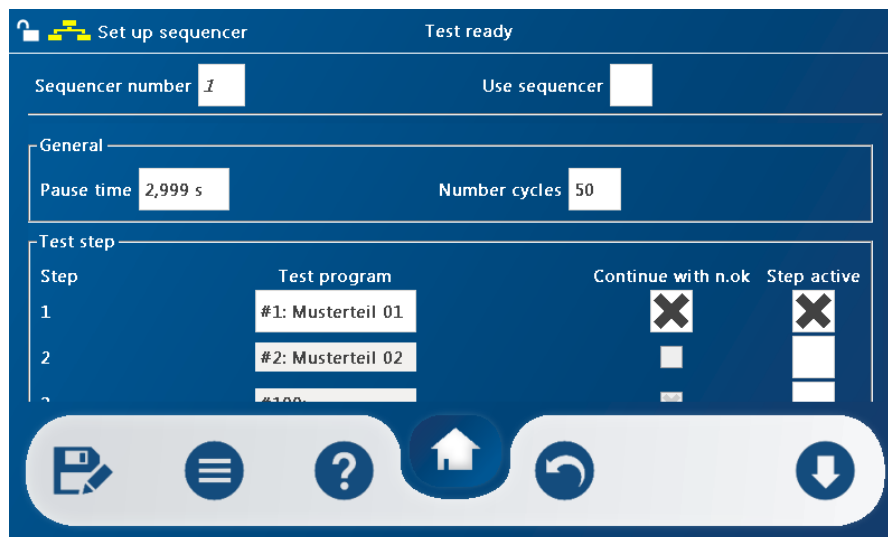

Figure 37: Dialog window Set up Sequencer

- Turn the key switch clockwise to input mode, make the following entries.

Sequencer number

Push the button to open the "Sequencer number" input field and, using the virtual keyboard, enter a number between 1 ... 10

Use Sequencer

Activate/deactivate the Sequencer by pressing the check box next to "Use Sequencer".

Pause time

Pause time in seconds from 0.10 ... 999.99
The default value is 30.00 sec.

The pause time is the time period to the start of the next sequencer cycle

Number of cycles

Cycles from 1 ... 9999
Default value is 1

With the sequencer activated the sequences are repeated as often as specified under the item "Cycles" when setting up the sequencer for the corresponding sequencer program.

Step active

Select to activate/deactivate the desired steps by pressing the check box next to the "Step active"

Parameter set

For the steps of the test sequence enter a test program using the numbers 1 ... 99



Continue for NOK

For each step of the test sequence, you can determine, by pressing the check box under "Continue for NOK" whether the next step of the test sequence will be executed:



NOTE!

Sequence parameters can be saved after input of a parameter or by

- all parameters by pressing the button  or by
- turning the keyswitch into position  .

Printout sequencer (test parameters)

Here you can decide whether the sequence parameters should be shown on the display or be printed out via an interface. Additionally you can select which sequence parameters should be displayed or printed out.

In the **MAIN MENU** under **SET UP** you will find the dialog window **SET UP**.

In the **SET UP** menu under **TEST PROGRAM** you can input the desired test program number.

The program parameters will be shown in the display.

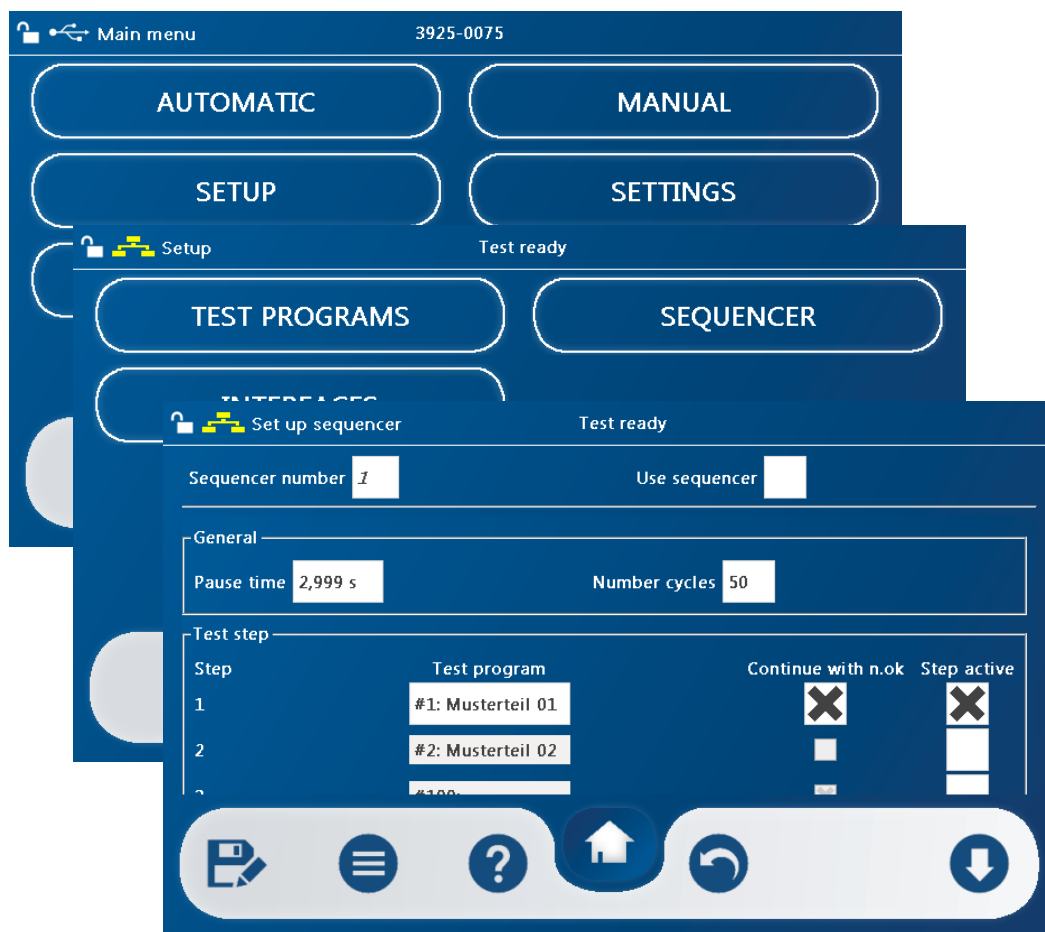



Figure 38: Dialog window data output Sequencer

- Press key  to activate the dialog window PRINT DATA for data transfer via one of the interfaces.

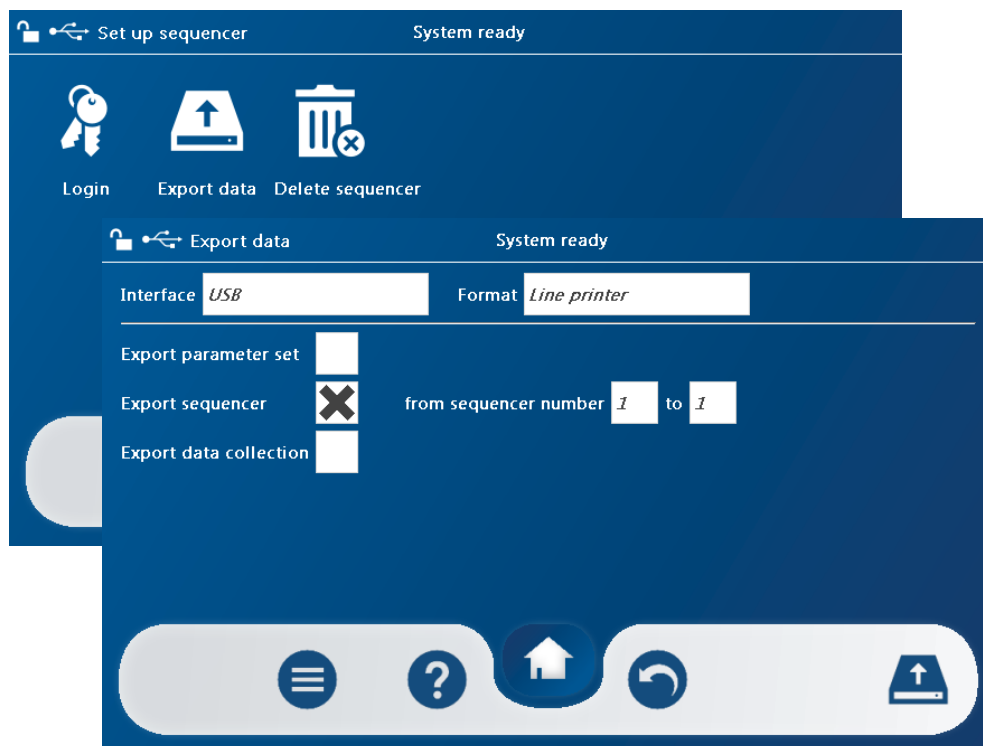



Figure 39: Dialog window data output Sequencer

- The Export window open by pressing 
- Select the interface to be used in the "Interface" input menu
- Select the output format to be used in the "Format" input menu.
- Select the Sequencer number(s) to be exported

NOTE!



A detailed list of possible interfaces and formats is found in the Appendix [Data output formats](#)

- Plug in the USB stick and start data export by pressing on 
Only pull out the USB stick after the progress bar has disappeared.

Interfaces

In the dialog window **SET UP INTERFACES** you can set up or change interface(s). The 1st serial interface TCP/IP and USB are available as standard. The fieldbus interface is optional.

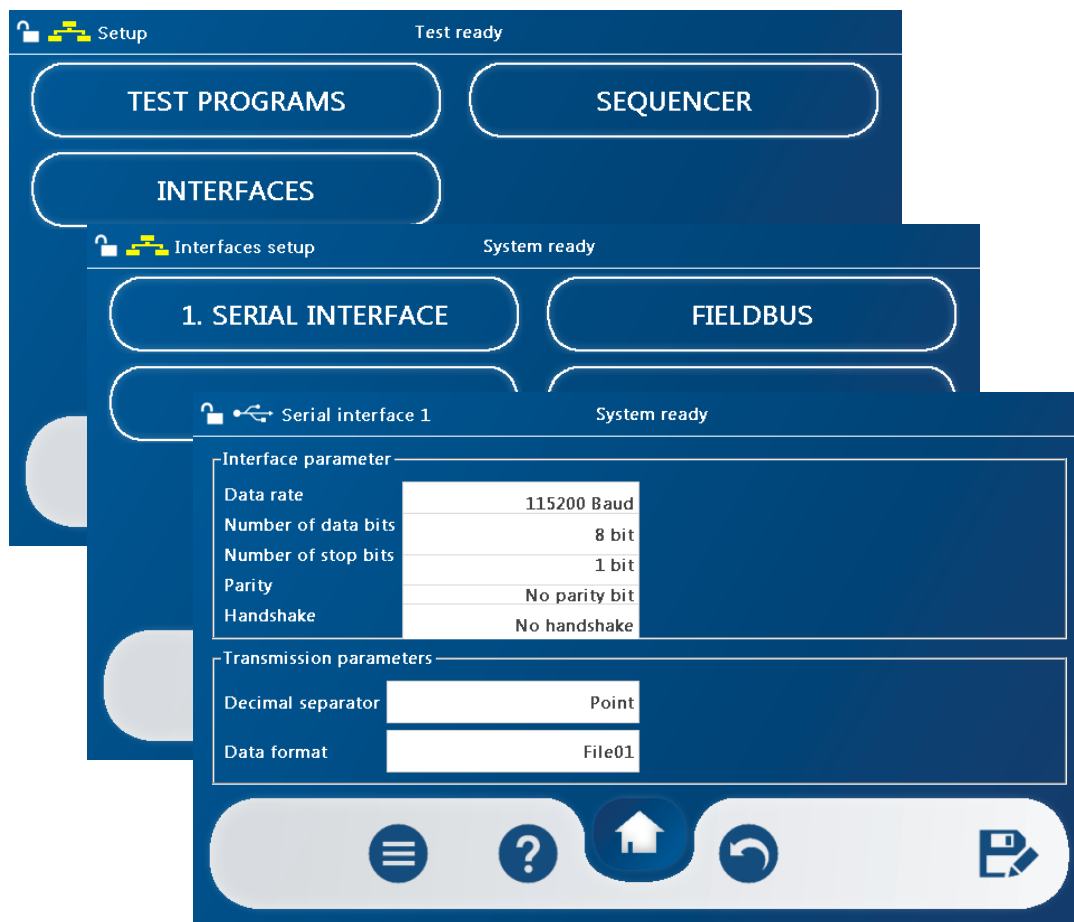



Figure 40: Dialog window Set up 1st Serial interface

Set up the 1st serial interface

- Turn key switch clockwise. Write protection is disabled, entries can be made.
- Make all following entries into the input field and confirm individually by pressing 

Data rate

- With the help of the scroll bar and the  and  buttons, you can select the transfer speed

Number of data bits

You can select the number of data bits by pressing a key in the input field

Number of stop bits

You can select the number of stop bits by pressing a key in the input field

Parity

You can select the type of parity test by pressing a key in the input field

Handshake

You can determine the transfer protocol by pressing a key in the input field

Decimal separator

You can determine the decimal separator by pressing a key in the input field

Data format

You can determine the data format by pressing a key in the input field

The following formats are available to choose from:

- No data output
- File 01
- File 02
- Line printer
- Filling curve (text)

NOTE!

The output format **File 01**, **File 02** and **Filling curve(Text)** are an easy way to transfer measurement results to a PC. This will only output the measuring results of the currently running test.

The following sections contain further information to the individual interface formats.

Once you have made and checked all entries, you can save these data.

- Return the keyswitch to the vertical position again for write protection, so the device saves the changed data

NOTE!

The interface type is determined by the hardware and cannot be changed by the program.

Output format File01

Set up / change the interface for format File01 for data output to a PC.

Using the example **Serial Interface 1**, this section explains how to set up the output format for the output **File01** and **File02** and which data will be output by the test device 3925-0075.

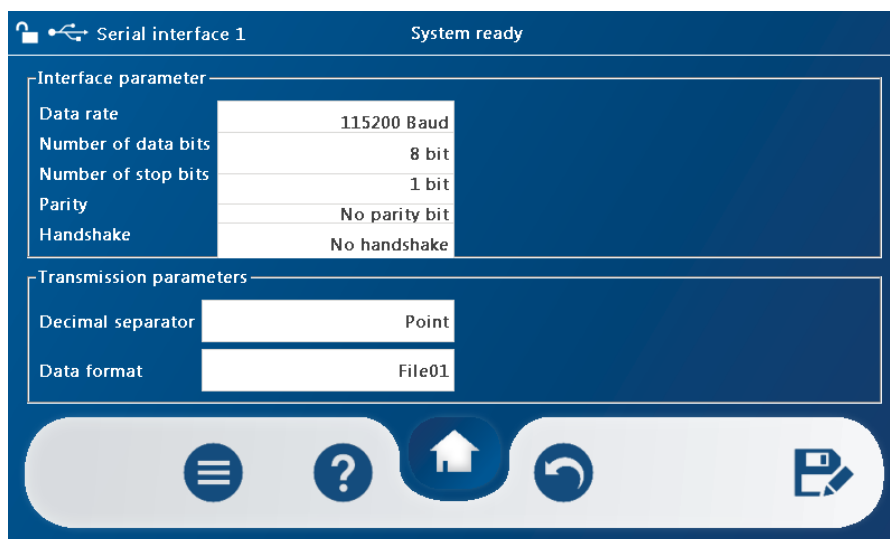

Figure 41: Dialog window - Output of file format - File 01

In order to set up an interface for the output of measuring data to a PC, you should select the **format**: Select **File01** or **File02**.

These output files differ by the amount of measuring data.

The measuring data of File01

Output format **File01** consists of 8 measuring results in numerical format, each divided by a semicolon. Example of a measuring result:

00000001;	01;	01022004;	152621;	000000;	01;	01;	00
SeqNo;	Pg;	DyMtYear;	HrMnSc;	Measva;	Unt;	Rs;	Er; ...
							Error number in 2 digits
							Result in 2 digits
							Unit in 2 digits
							Measuring value in 6 digits
							Hour Minute Second in 6 digits
							Day Month Year in 8 digits
							Program number in 2 digits
							Consecutive number in 8 digits

Consecutive number

The consecutive number consists of 8 positions and is from 00000001...99999999. Once the counter has reached 99999999, it will automatically restart at 00000001.

Program number

The number of the executed test program in the range from 01 ... 99

Day Month Year

The date of testing consists of 8 digits: 2 digits for the day, 2 digits for the month, 4 digits for the year

Hour Minute Second

The time of testing consists of 6 digits. 2 digits each for hour, minute and second

MeasVal

The measured value with floating point representation matches the chosen unit. The output width is always 6 digits. Error messages or the measuring result "Coarse Leak" are represented by 6 minus dashes.

Unit

The two-digit numerical value indicates the unit of the executed test program:

01 = Pa

02 = mbar

03 = PSI

04 = mmWs

05 = mmHg

06 = ml/min

Result

The two-digit numerical value indicates the measuring result of the executed test program:

01 = Accept / OK

02 = Rework / LT

03 = Leak / UT

04 = Leak / Coarse Leak (Major leak)

-- = Error messages are identified by 2 minus dashes.

Error number:

The two-digit numerical value indicates the type of the error of the executed test program that has occurred:

03	Program missing	04	Transmitter defective
10	Coarse leak in reference volume	13	Leak in reference volume
14	Series fault	18	Limit contact "Leak" cannot be reached
23	Filling pressure too low	24	Filling pressure to high
25	Test pressure too low	26	Test pressure to high
27	Pressure system not adjustable	37	Test pressure in sequence too low
38	Test pressure in sequence too high		

The output of some of the error numbers depends on device type or options. If the number of the error code is ≤ 0 , minus symbols will be displayed for measuring value and measuring result.

If a numerical value cannot be displayed in the defined output format, the field will be stated by "↑↑↑↑↑↑" (Code 18H) when exceeded, or by "↓↓↓↓↓↓" (Code 19H) when fallen short of. The individual positions are separated by semicolon. The data set is closed with a carriage return and a line feed (CR+LF).

Examples:

No Leak	00000001;01;01022000;152621;000000;01;01;00
Gross leak (major leak)	00000002;01;01022000;152637;-----;01;04;00
Fault	00000003;01;01022000;152718;-----;01;--;25

Output format File02

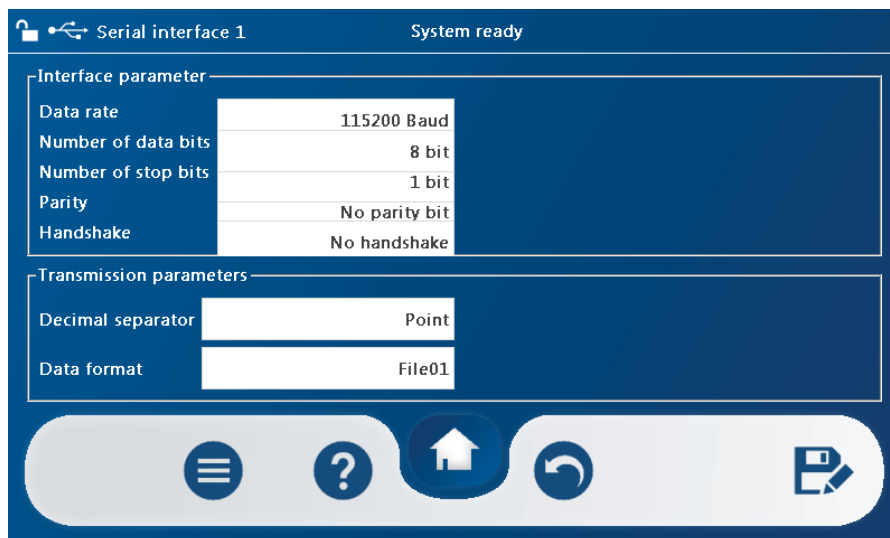

Figure 42: Dialog window - Output the data format - File02

The measuring data of File02

If you choose the format **File02** for the data output, five more measuring data will be output in addition to the measuring data of format File01, i.e. a total of 13, which are each separated by semicolon.

Example of a measuring result:

00000001;01;24022002;152621;000000;01;01;00;001,00:003,00;1,0000000;000050;000100
(here NO LEAK)

SeqNo;	Pg;	DyMtYear;	HrMnSc;	Measva;	Unt;	Rs;	Er; ...
							Error-No. in 2 digits
							Result in 2 digits
							Unit in 2 digits
							Measuring value in 6 digits
							Hour Minute Second in 6 digits
							Day Month Year in 8 digits
							Program number in 2 digits
							Consecutive number in 8 digits

Continued

... Test pressure;	Measuring time;	Volume factor;	Rework;	Leak
				Leak in 6 digits
			Rework in 6 digits	
		Volume factor in 8 digits		
	Measuring time in 6 digits			
Test pressure in 6 digits				

In addition to the measuring data in format **File01**, format **File02** will also provide the following data:

Test pressure

Indicates the test pressure for the test in 6 digit. The output width is always 6 digits. The unit for the test pressure is barg

Measuring time

Shows the entered measuring time in a structured representation. The unit for the measuring time is seconds

Volume factor

Shows the volume multiplier, used to calculate the measuring values, in a structured representation. The output width is always 8 digits

Rework

Indicates the limit contact for rework in the adapted structured representation. The output width is always 6 digits

Leak

Indicates the limit contact for leak in the adapted structured representation. The output width is always 6 digits

Examples for the output of measuring data in the format File02

No Leak

00000001;01;24022002;152621;000000;01;01;00;1,00;3,00;1,0000000;50;100

Gross leak (major leak)

00000002;01;24022002;152637;-----;01;04;00;1,00;3,00;1,0000000;50; 100

Fault

00000003;01;24022002;152718;-----;01; --;25;1,00;3,00;1,0000000;50; 100

Setting up the fieldbus interface (optional)

Profibus

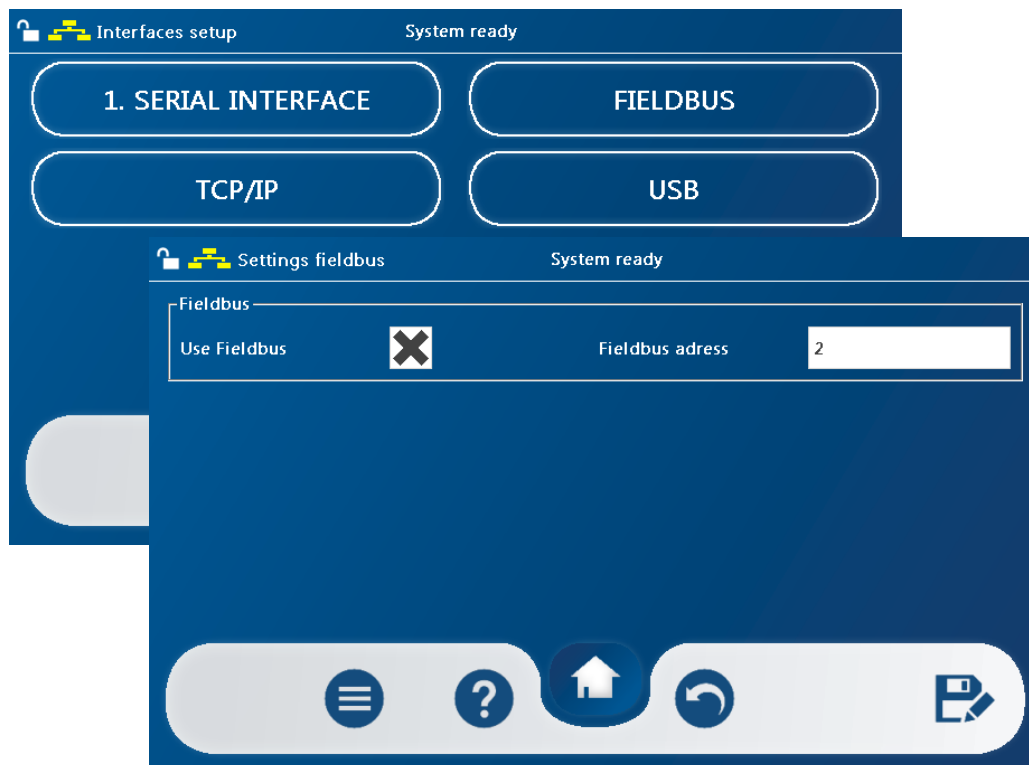

Figure 43: Dialog window Setting up interfaces - Profibus

If you would like to set up the Profibus as a fieldbus interface, it can be set up in the "Dialog window Set up interfaces – Profibus".

Profibus functions

The Profibus module supports a maximum Profibus data rate of 128 byte input and 128 byte output data as well as all baud rates from 9.6 kbit/s to 12 Mbps. Baud rate detection is performed automatically. The Profibus module implements the complete scope of function of a profibus DP-slave.

The Profibus address can be set up via the menu

SET UP \ INTERFACES \ Fieldbus.

Make the following settings in the dialog window Fieldbus settings:

Use fieldbus

Activate/deactivate the interface by pressing the check box next to "Use fieldbus"

Fieldbus address

Enter the desired address from 0...99 by pressing the input field next to "Fieldbus address"

Confirm with a push on  and save the settings with 

**NOTE!**

The interface format is defined by the hardware and cannot be changed via the program.

For devices with Profibus, you require the GSD file for configuring the Profibus Master, this file is delivered on a separate USB-Stick.

Profinet

Figure 44: Dialog window Setting up interfaces - Profinet

If you would like to set up the Profinet as a fieldbus interface, it can be set up in the "Dialog window Set up interfaces – Profinet".

Profinet-Functions

The Profinet module supports a maximum data rate of 1440 byte input and 1440 byte output data as well as a data rates of 100 Mbit/s. The Profinet module implements the complete scope of function of a Profinet slave.

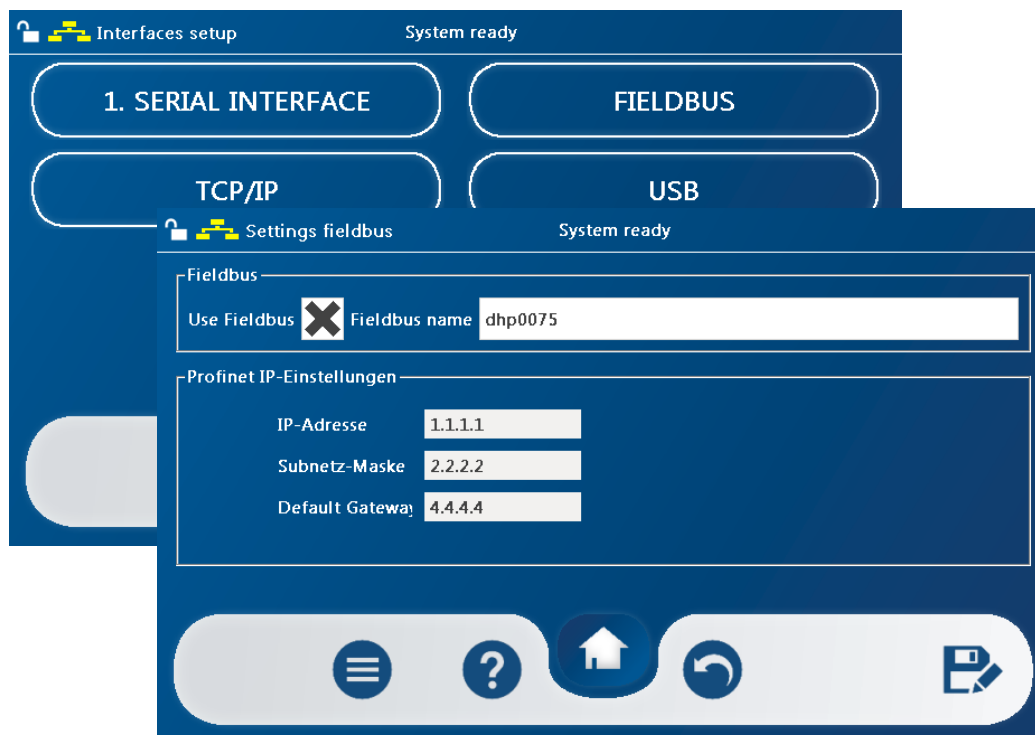
The Profinet name can be set up via the menu

SET UP \ INTERFACES \ Fieldbus

Make the following settings in the dialog window Fieldbus settings:

Use fieldbus

Activate/deactivate the interface by pressing the check box next to "Use fieldbus"

Fieldbus name

Enter the desired name by pressing the input field next to "Fieldbus name" The naming conventions of Profinet must be observed.

Confirm by pressing  and save the settings with 

**NOTE!**

The interface format is defined by the hardware and cannot be changed via the program.

For devices with Profinet you require the GSDML-file for configuring the Profinet Master, this file is delivered on a separate USB-Stick.

Fieldbus interface inputs and outputs – Profibus\Profinet

If the fieldbus is activated, the following inputs/outputs are available depending on the module selected in the GSD-\GSDML file

Module	Leak tester control input		
Type	Byte/Bit	3925-0075 Leak tester	Data type
Input	0.0	Machine ready	
Input	0.1	Start	
Input	0.2	Leak	
Input	0.3	Flooding	
Input	0.4	Abort	
Input	0.5	Automatic	
Input	0.6	Output parameter	
Input	0.7	Accept parameter	
Input	1.0	BCD 01 (Program selection)	1 binary
Input	1.1	BCD 02 (Program selection)	2 binary
Input	1.2	BCD 04 (Program selection)	4 binary
Input	1.3	BCD 08 (Program selection)	8 binary
Input	1.4	BCD 10 (Program selection)	10 binary
Input	1.5	BCD 20 (Program selection)	20 binary
Input	1.6	BCD 40 (Program selection)	40 binary
Input	1.7	BCD 80 (Program selection)	80 binary

Module		Leak tester control output	
Type	Byte/Bit	3925-0075 Leak tester	Data type
Output	0.0	Ready for operation	
Output	0.1	Fault	
Output	0.2	Ready for test	
Output	0.3	Rework / LT	
Output	0.4	Leak / UT	
Output	0.5	Accept / OK	
Output	0.6	Envelope curve/filling NOK/volumes NOK	
Output	0.7	Measurement active	
Output	1.0	Data ready	
Output	1.1	Reserve	
Output	1.2	Reserve	
Output	1.3	Reserve	
Output	1.4	Reserve	
Output	1.5	Reserve	
Output	1.6	Reserve	
Output	1.7	Reserve	

Module		Measurement result output part 1	
Type	Byte/Bit	3925-0075 Leak tester	Data type
Data output	Byte 0	SeqNo. digit 1	
Data output	Byte 1	SeqNo. digit 2	
Data output	Byte 2	SeqNo. digit 3	
Data output	Byte 3	SeqNo. digit 4	
Data output	Byte 4	SeqNo. digit 5	
Data output	Byte 5	SeqNo. digit 6	
Data output	Byte 6	SeqNo. digit 7	
Data output	Byte 7	SeqNo. digit 8	
Data output	Byte 8	SeqNo. Semicolon	
Data output	Byte 9	Program number digit 1	
Data output	Byte 10	Program number digit 2	
Data output	Byte 11	Program number semicolon	
Data output	Byte 12	Day digit 1	
Data output	Byte 13	Day digit 2	
Data output	Byte 14	Month digit 1	
Data output	Byte 15	Month digit 2	
Data output	Byte 16	Year digit 1	

Module	Measurement result output part 1		
Type	Byte/Bit	3925-0075 Leak tester	Data type
Data output	Byte 17	Year digit 2	
Data output	Byte 18	Year digit 3	
Data output	Byte 19	Year digit 4	
Data output	Byte 20	Day/Month/Year semicolon	
Data output	Byte 21	Hour digit 1	
Data output	Byte 22	Hour digit 2	
Data output	Byte 23	Minute digit 1	
Data output	Byte 24	Minute digit 2	
Data output	Byte 25	Second digit 1	
Data output	Byte 26	Second digit 2	
Data output	Byte 27	Hour/minute/second	
Data output	Byte 28	Measuring value in digit 1	
Data output	Byte 29	Measuring value in digit 2	
Data output	Byte 30	Measuring value in digit 3	
Data output	Byte 31	Measuring value in digit 4	
Data output	Byte 32	Measuring value in digit 5	
Data output	Byte 33	Measuring value in digit 6	
Data output	Byte 34	Measurement semicolon	
Data output	Byte 35	Unit digit 1	
Data output	Byte 36	Unit digit 2	
Data output	Byte 37	Unit semicolon	
Data output	Byte 38	Result digit 1	
Data output	Byte 39	Result digit 2	
Data output	Byte 40	Result semicolon	
Data output	Byte 41	Error number digit 1	
Data output	Byte 42	Error number digit 2	
Data output	Byte 43	Error number semicolon	
Data output	Byte 44	Test pressure in digit 1	
Data output	Byte 45	Test pressure in digit 2	
Data output	Byte 46	Test pressure in digit 3	
Data output	Byte 47	Test pressure in digit 4	
Data output	Byte 48	Test pressure in digit 5	
Data output	Byte 49	Test pressure in digit 6	
Data output	Byte 50	Test pressure semicolon	
Data output	Byte 51	Measuring time in digit 1	
Data output	Byte 52	Measuring time in digit 2	
Data output	Byte 53	Measuring time in digit 3	
Data output	Byte 54	Measuring time in digit 4	

Module		Measurement result output part 1	
Type	Byte/Bit	3925-0075 Leak tester	Data type
Data output	Byte 55	Measuring time in digit 5	
Data output	Byte 56	Measuring time in digit 6	
Data output	Byte 57	Measurement time semicolon	
Data output	Byte 58	Volume factor in digit 1	
Data output	Byte 59	Volume factor in digit 2	
Data output	Byte 60	Volume factor in digit 3	
Data output	Byte 61	Volume factor in digit 4	
Data output	Byte 62	Volume factor in digit 5	
Data output	Byte 63	Volume factor in digit 6	

NOTE!

A detailed list of other formats can be found in the appendix



[Data format fieldbus](#)

NOTE!

For devices with Profibus or Profinet, the GSD-\GSDML file is required to configure the Profibus-\Profinet Master. This is supplied on a separate data carrier.



Parameterisation of a test program via the fieldbus

To parameterise a test program, the following areas of the fieldbus interface are relevant:

1. Input Transfer parameter:
This data block the control system transfers the ID of the current parameters and in the case "Accept parameters", the other length details and parameter values according to the interface definition.
2. Output Parameter Transfer:
This data block writes to the leak tester:
 - a. In the case "Output parameters" the value currently saved in the leak tester which is queried by the controls.
 - b. In the case "Accept parameters" the mirrored values of the parameters changed by the controls.
 - c. In case of an error, an error code that provides further information on the cause of the error.
3. The Bits "Output parameters", "Accept parameters" and "Data ready" in the digital input and output bytes.
A handshake protocol is implemented with these bits.
 - a. The controls beckon that all data in input data block 1 is consistent and the leak tester should start with an action (output, accept, save program, delete program).
 - b. The leak tester beckons, by setting "Data ready", that a consistent answer is present in the output data block.

The relevant Bits in the digital input and output Bytes are shown below in colour.

Digital inputs:

	Bit							
Byte	7	6	5	4	3	2	1	0
0	Accept parameter	Output parameter	Automatic	Abort	Flooding	Leak	Start	Machine ready
1	Program number							

Digital outputs:

	Bit							
Byte	7	6	5	4	3	2	1	0
0	Measuring active	Envelope curve, ... NOK	Accept / OK	Leak/ UT	Rework LT	Ready for test	Fault	Operation-ready
1								Data ready

Note: The program number in byte 1 of the digital inputs defines the program currently used for tests. This parameter is not used when parameterizing the test programs and can be used independently of it.

Handshake principle

The following illustration clarifies the handshake principle implemented for each individual step.

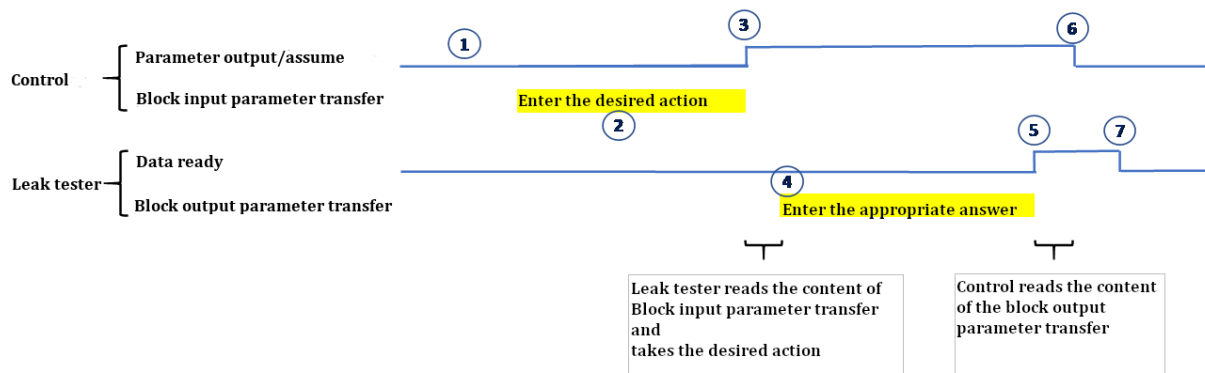

1. In the initial situation, all control bits are set to the value zero. The content of the parameter transfer blocks is arbitrary.
2. First, the controller writes to the Input Parameter Transfer block according to the desired action.
3. By setting one of the control bits "Output parameter" or "Accept parameter", the control state to the leak tester that the data in the input parameter transfer block are complete and that the leak tester should begin the corresponding action.
4. The leak tester now reads the content of the block, carries out the desired action - if possible - and fills the response into the Output Parameter Transfer block.
5. As soon as the response in the output block is completed, the leak tester sets the "Data ready" bit.
6. The controls can now read out and evaluate the response. By resetting the "Output parameter" or "Accept parameter" control bit, the controller indicates that the evaluation has been completed.
7. The leak tester then also resets the "Data ready" control bit and the system is back in its initial state.

Specific parameters (pseudo parameters)

Specific parameter indices besides the normal range of the parameter indices are defined for executing actions for saving a test program in the database or for deleting it from the database. A write command to these parameter indices is interpreted as a command by the leak tester. The following table shows the defined values:

Value	Definition	Behavior of the leak tester
256	Save program	The temporarily created test program is saved in the database
512	Delete program	The program with the program number of the temporary test program is deleted from the database

For the response from the leak tester output parameter block, parameter number 255 is used to negatively acknowledge a command from the controller (see chapter on error messages).

Processes

Depending on the desired action, certain rules and sequences must be observed.

General start by writing a program number

All parameterisation actions begin with the selection of the test program by executing a write command for parameter index 1 (program number). The program number is used as an index in the database and therefore has a specific meaning.

When a write command is received on parameter index 1, a new parameterisation process always begins for the leak tester. Any processes started previously are discarded.

Case 1: a program with the selected program number already exists in the leak tester database: the temporary object is created as a copy of the existing test program.

Upon receipt of the write command, the leak tester creates a temporary test program object to which the following commands are applied:

Case 2: a program with the selected program number does not yet exist in the leak tester database: the temporary object is filled with the default values of a test program.

Possible errors that are negatively acknowledged by the leak tester:

1. ERROR_CODE_PARAMETER_LENGTH_FAILURE:
Error in the length parameters of the write command.
2. ERROR_CODE_PROG_NR_OUT_OF_RANGE:
Specified program number not allowed.

Writing and saving of program parameters

After selecting the program number, the control can send write commands for all parameters of the test program.

The writing process is completed by writing the pseudo parameter 256 (save program). If there are no errors, the leak tester saves the temporary copy in its database.

The following rules apply here:

1. Write commands for all parameters of the test program are to be sent in the correct order. The leak tester monitors the correct sequence with a sequence counter.
 - a. If the leak tester receives a write command for a parameter outside of this sequence, the write command is acknowledged negatively. The sequence counter remains at the expected parameter number.
 - b. The only exception to this rule is the "Date" parameter, as this is always set in the device when it is saved in the database. If this parameter is written, the leak tester ignores the write command. Otherwise the next following parameter is expected.
2. The command to save the test program is only executed if all program parameters have been written in the correct order. If not, the save command is acknowledged negatively and the missing parameters are waited for.
3. If the device is restarted before the command to save in the database has been carried out successfully, the changes made during the last active parameterisation process are lost.
4. Writing the program number again is interpreted as an abortion of the process. The leak tester discards the values in the temporarily created test program and begins a new process.
5. Program parameters related to measuring units (IDs 27 and 29) are interpreted in the unit previously written and internally converted to Pascal.
6. Read commands between the write commands are accepted and executed by the leak tester at any time.

Possible errors that are negatively acknowledged by the leak tester:

1. **ERROR_CODE_PARAMETER_LENGTH_FAILURE:**
Error in the length parameters of the write command.
2. **ERROR_CODE_ID_OUT_OF_RANGE:**
Invalid parameter number
3. **ERROR_CODE_INPUT_PAR_OUT_OF_RANGE:**
Invalid value of the parameter to be written

4. **ERROR_CODE_SET_ID_NOT_SUPPORTED:**
Parameter could not be written by the control. This negative acknowledgment is sent with a write command on the date parameter.
5. **ERROR_CODE_NO_PROGRAM_SELECTED:**
Write command for a parameter received without a valid program number having been previously written.
6. **ERROR_CODE_ID_SEQUENCE_FAILURE:**
The order of the parameters was not respected
7. **ERROR_CODE_DATABASE_FAILURE**
Saving the test program in the database failed

Reading of program parameters

It is always possible to read test program parameters if there is a temporary object of a test program available in the leak tester.

This means that a test program must be selected beforehand with a write command to the first parameter (program number) and the process must not yet have been completed with a save or delete command.

In principle, reading can take place in any order and is also accepted by leak tester between write commands. The parameters of the temporarily created test program are always used (not the database).

Possible errors that are negatively acknowledged by the leak tester:

1. **ERROR_CODE_ID_OUT_OF_RANGE:**
Invalid parameter number
2. **ERROR_CODE_NO_PROGRAM_SELECTED:**
Read command for a parameter received without a valid program number having been previously written.

Deletion of test programs

The deletion of test program parameters is instructed by the control to write pseudo-parameter 512.

The control can write the delete command at any time if a program number has been selected beforehand. This also applies if individual parameters have already been written.

With the delete command, the test program with the selected program number is removed from the leak tester database. The temporarily created test program is discarded.

Possible errors that are negatively acknowledged by the leak tester:

1. **ERROR_CODE_NO_PROGRAM_SELECTED:**
Delete command received without a valid program number having been previously written.

Error detection and acknowledgment

The leak tester checks the values in the Parameter Transfer input each time it receives a command.

If an inconsistency is found, an error message in the parameter transfer output signals to the control that the process could not be carried out in meaningful way. The values received from the controller are discarded.

Structure of error messages

When structuring an error message, consideration is given to ensure the basic structure matches the expected structure (parameter ID, max/actual length of the following Bytes)

A **pseudo-parameter-ID of 255** is defined for the error message, that the controls recognise as not being a parameter mirror but rather a negative acknowledgement.

The following values for maximum and actual length of the subsequent data is defined as 29. This number results from the maximum possible number of Bytes in the Parameter Transfer input plus one Byte for the error code.

The error code indicates the reason for rejecting the read or write command.

The data behind the error code mirror the data in the Parameter Transfer input to give the controls more information about the cause of error, if required.

Byte	Description	Explanation
0	Pseudo-Parameter-ID, digit 1	Special parameter ID for error messages: 255 (0x00FF)
1	Pseudo-Parameter-ID, digit 2	
2	Error parameter, max. length (29)	Max. largest expected input message
3	Error parameter, actual length (29)	24 Byte (names) + 4 Byte header + 1 Byte error code
4	Error code	Contains the reason for rejection
5	Mirror Rx Byte 1	Mirror of the data read out from Parameter Transfer input
6	Mirror Rx Byte 2	
7	Mirror Rx Byte 3	
8	Mirror Rx Byte 4	
9	Mirror Rx Byte 5	
10	Mirror Rx Byte 6	
11	Mirror Rx Byte 7	
12	Mirror Rx Byte 8	
13	Mirror Rx Byte 9	
14	Mirror Rx Byte 10	

Byte	Description	Explanation
15	Mirror Rx Byte 11	
16	Mirror Rx Byte 12	
17	Mirror Rx Byte 13	
18	Mirror Rx Byte 14	
19	Mirror Rx Byte 15	
20	Mirror Rx Byte 16	
21	Mirror Rx Byte 17	
22	Mirror Rx Byte 18	
23	Mirror Rx Byte 19	
24	Mirror Rx Byte 20	
25	Mirror Rx Byte 21	
26	Mirror Rx Byte 22	
27	Mirror Rx Byte 23	
28	Mirror Rx Byte 24	
29	Mirror Rx Byte 25	
30	Mirror Rx Byte 26	
31	Mirror Rx Byte 27	
32	Mirror Rx Byte 28	

Error codes

Value	Description	Explanation
1	ERROR_CODE_PROGRAM_NUMBER_UNKNOWN	Only when reading parameters: Program number permitted, but no test program with this number stored in the leak tester.
2	ERROR_CODE_ID_OUT_OF_RANGE	Parameter ID is out of valid Area
3	ERROR_CODE_PROG_NR_OUT_OF_RANGE	Program number outside the valid range
4	ERROR_CODE_INPUT_PAR_OUT_OF_RANGE	The parameter value is outside the valid range of values
5	ERROR_CODE_SET_ID_NOT_SUPPORTED	Only when accepting parameters: the selected parameter cannot be written
6	ERROR_CODE_PARAMETER_LENGTH_FAILURE	Maximum or current length do not match to the parameter
7	ERROR_CODE_NO_PROGRAM_SELECTED	No program currently selected.
8	ERROR_CODE_DATABASE_FAILURE	Error when saving the test program in the database.
9	ERROR_CODE_ID_SEQUENCE_FAILURE	Write command to a parameter number that does not correspond to the expected sequence number.

TCP/IP

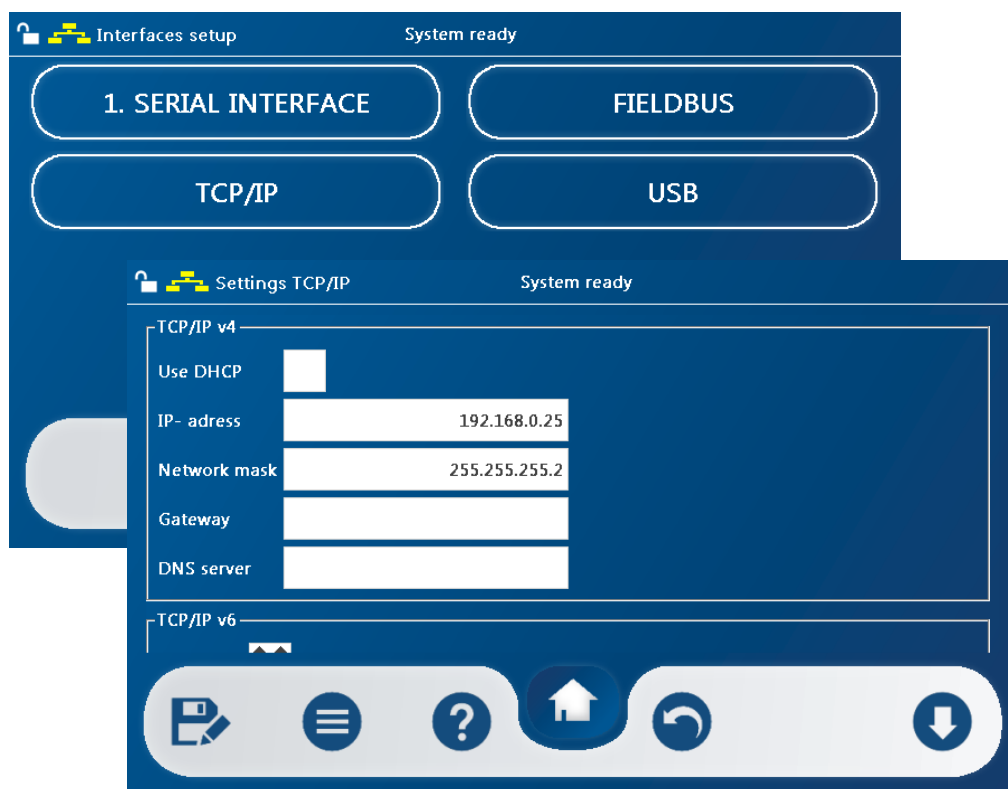

Figure 45: Dialog window Setting up interfaces - TCP/IP v4

You can set up the TCP/IP interface for the VNC connection. For a VNC installed on the PC (e.g. UltraVNC Viewer)

TCP/IP v4

Use DHCP

Activate/deactivate the interface by pressing the check box next to "Use DHCP"

IP address

Enter the desired address by pressing the input field next to "IP address"

Network mask



Enter the desired network mask by pressing the input field next to "Network mask"

Gateway

Enter the desired address of the IP router by pressing the input field next to "Gateway"

DNS server

Enter the desired NS server address by pressing the "NS server" input field

Confirm with a push on  and confirm the settings with 

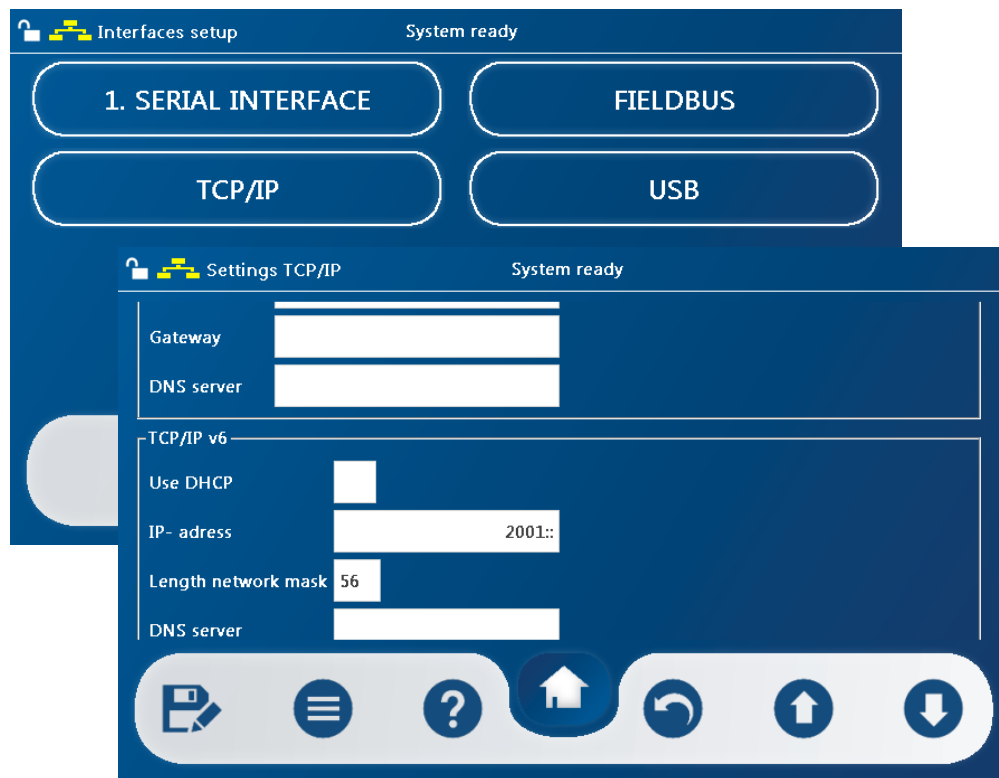

Figure 46: Dialog window Setting up interfaces - TCP/IP v6

TCP/IP v6

Use DHCP

Activate/deactivate the interface by pressing the check box next to "Use DHCP"

IP address



Enter the desired address by pressing the input field next to "IP address"

Network mask length

Enter the desired network mask by pressing the input field next to "Network mask"

DNS server

Enter the desired NS server address by pressing the "NS server" input field

Confirm with a push on  and confirm the settings with 

VNC

A VNC server is pre-installed in the leak testing device. You have the option to operate and monitor the device via a network connection using a VNC Viewer.

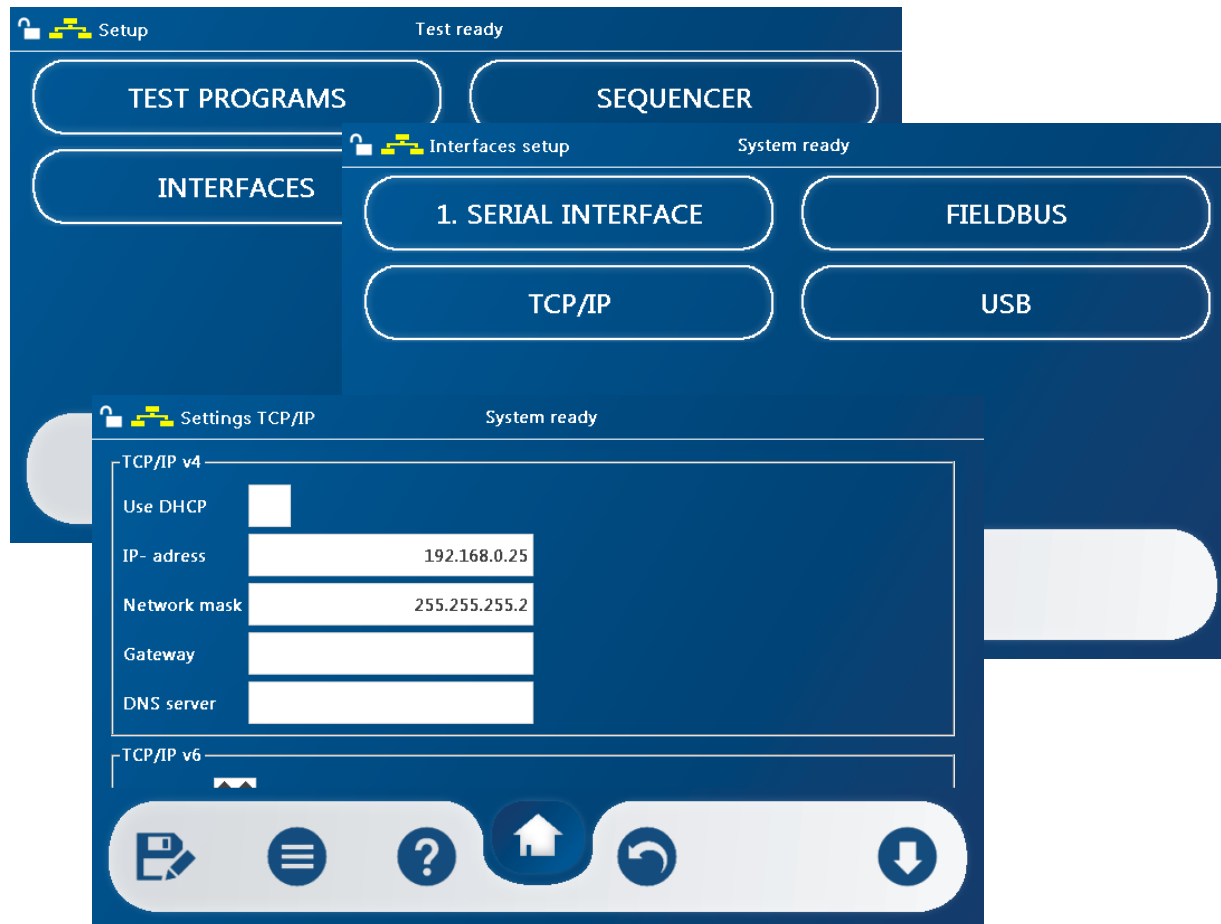

Figure 47: Dialog window Set up TCP/IP for a VNC server

To connect via the VNC Viewer, the device must be assigned an IP address on your network.

Install a VNC Viewer and enter the same IP address as assigned to your device.

Now you can connect to your leak tester with the VNC Viewer.

User level 2 is standard. Visible on the locked padlock in the menu bar at the top left.



User 2:

Operator

Now you can navigate through individual menus, e.g. test results stored in the menu Data Collection.

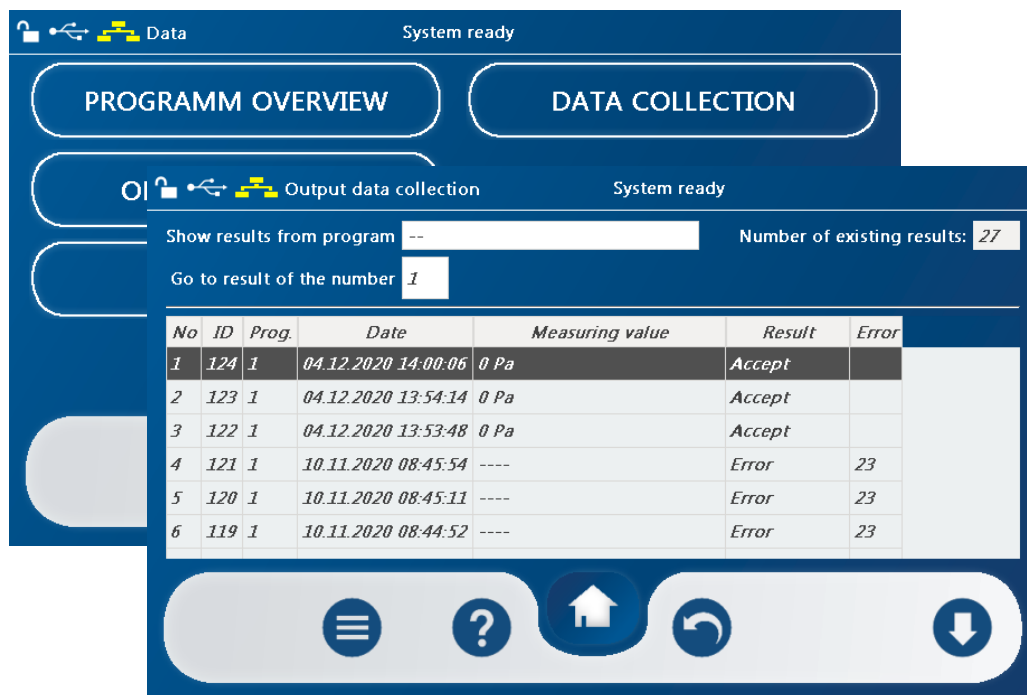

Figure 48: Dialog window File menu – Data collection

ATTENTION!



User level 2 has some functions available that could cause the leak tester to malfunction in certain situations. Be careful with any actions you take. It is not immediately visible to the local user that you have connected to the leak tester via the VNC Viewer.

Agree internally within the company how you organise remote access and use of the device on-site to avoid accidental errors or complications.

If you would like to operate your leak tester remotely by VNC, you must log in at user level 5. The password for this user level must be requested directly from HeMaTech Prüftechnik support.

ATTENTION!

In user level 5, you have the option of editing numerous settings remotely on the leak tester.



Be careful with any actions you take. It is not immediately visible to the user that they have connected to the leak tester via the VNC Viewer.

Agree internally within the company how you organise remote access and use of the device on-site to avoid accidental errors or complications.

NOTE!

If the keyswitch is used, while you are logged in to the leak tester via VNC, the device automatically switches to the selected user level 4. For this reason, decide internally, who, when and where the leak tester device is worked on.

If you have the password for user level 5, you can log in as follows:

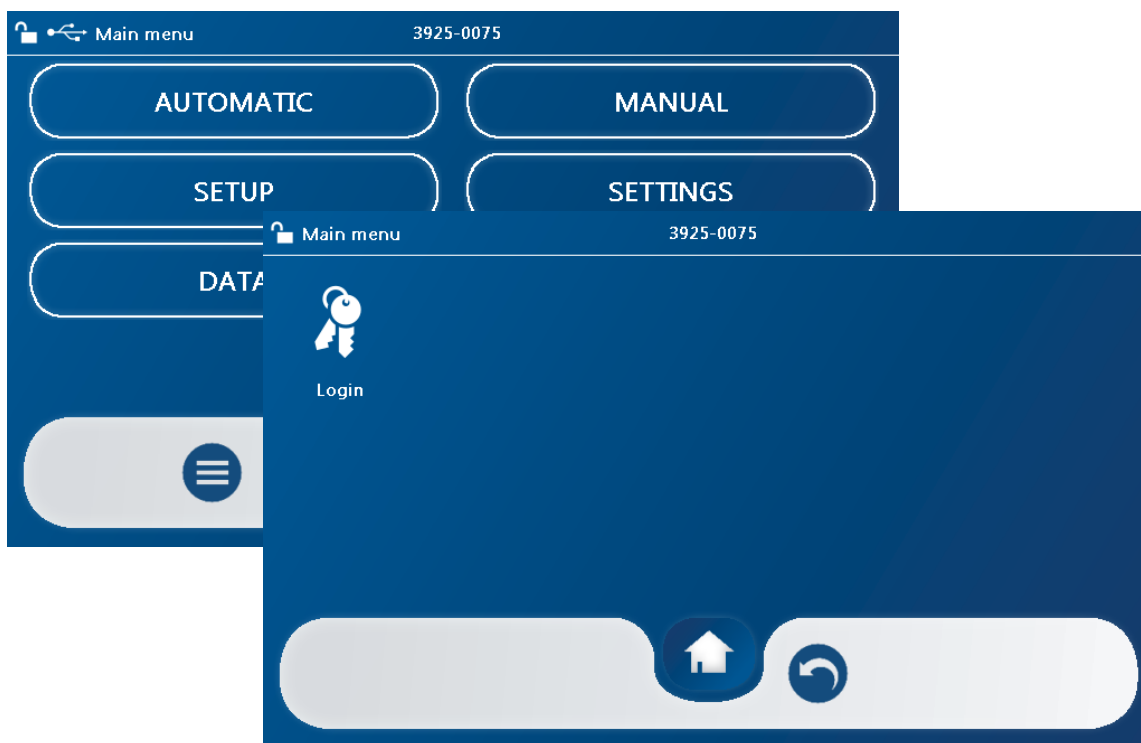

Figure 49: Dialog window Main menu Login window

- Call up the Context menu by pressing

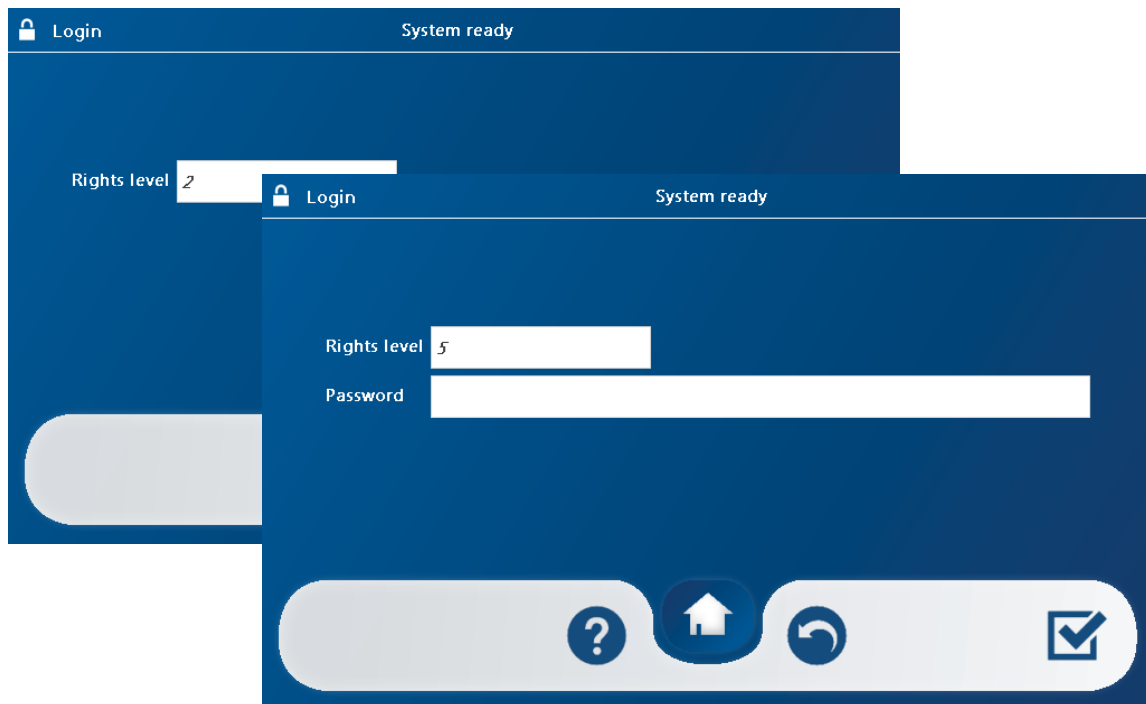



Figure 50: Dialog window Login VNC server

- Enter "5" by pressing the input field at the right and confirm with 
- Enter the password in the password input field and confirm with 

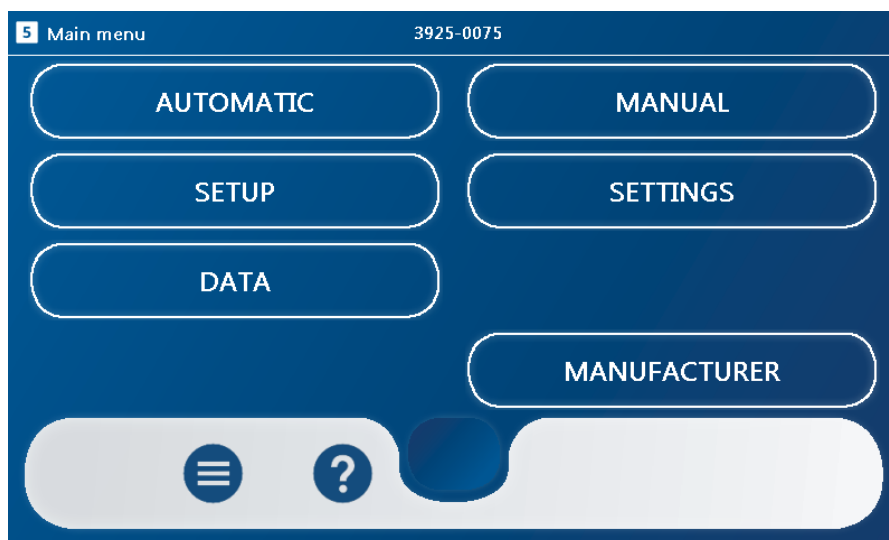

Figure 51: Dialog window user level 5 main menu

- After a successful login to user level 5, this dialog window is shown



NOTE!

After you have received the password for the VNC server you should **immediately change it.**

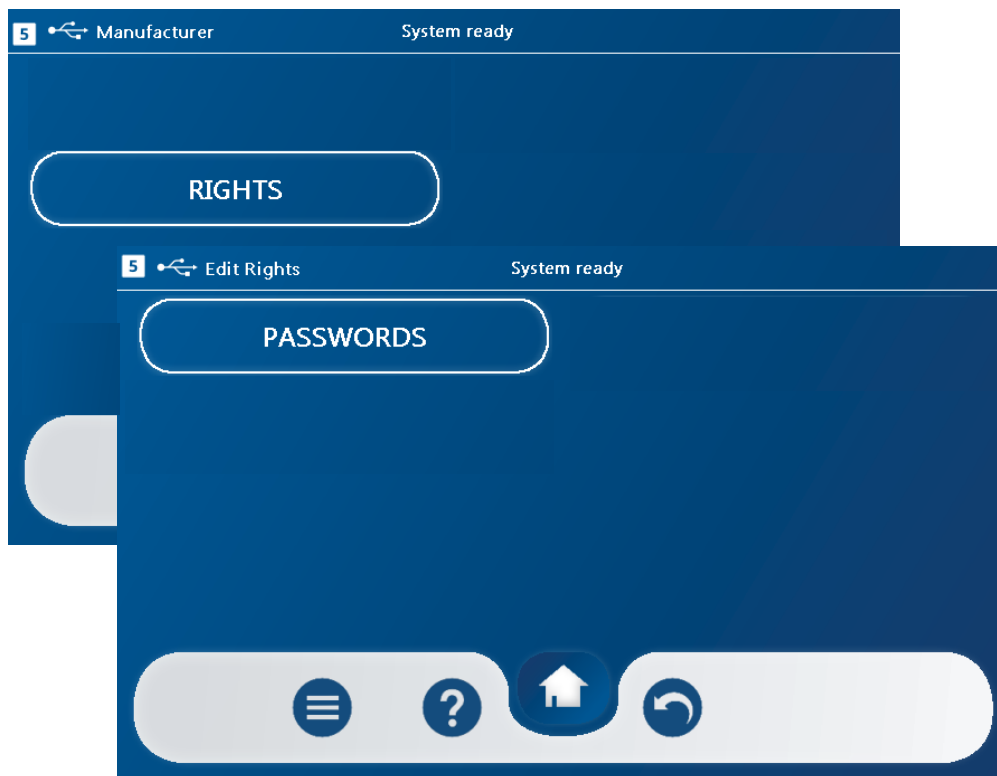

Figure 52: Dialog window edit Rights

- Change the password for user level 5 by pressing Manufacturer, Rights, Passwords

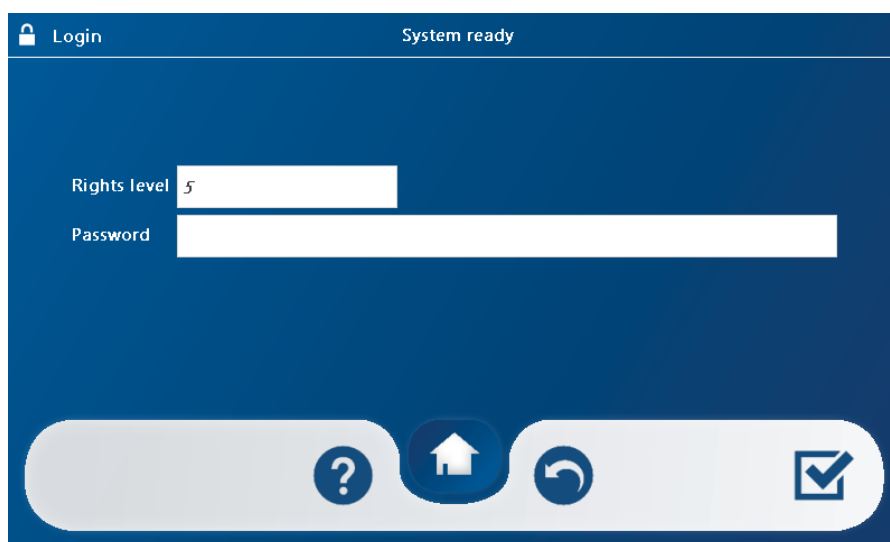



Figure 53: Dialog window Change password user level 5

- Assign a new password by pressing the input field for a new password and confirm with 

USB

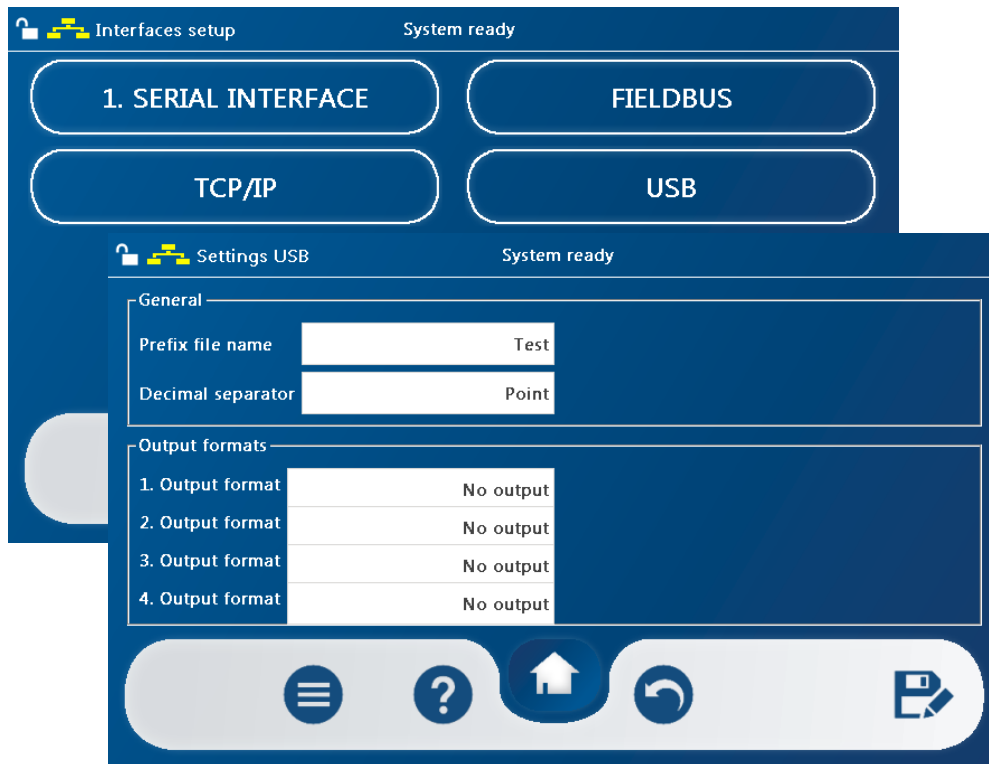

Figure 54: Dialog window Setting up interfaces - USB

File name prefix

Enter a prefix, if desired, by pressing the input field next to "File name prefix". For data output to a USB interface, the saved data has a prefix attached at the start. Example, prefix: Test , output file "TestDPG20100200_F01.csv".

Decimal separator

Select the desired separator by pressing the input field next to "Decimal separator".

Output formats

1. Output format

Select the desired format by pressing the input field next to "Output format"

2. Output format



Select the desired format by pressing the input field next to "Output format"

3. Output format

Select the desired format by pressing the input field next to "Output format"

4. Output format

Select the desired format by pressing the input field next to "Output format"

Confirm with a push on  and accept the settings with 



NOTE!

For a USB interface, up to 4 different output formats can be selected for simultaneous output.

Settings menu

In the **MAIN MENU** under **SETTINGS**, the dialog window **SETTINGS** can be found. Within this menu you can set the display, view system parameters, view the software version, change the pressure control, view input and output signals, set date and time, adjust decimal places, do a software update, set switch on masks and machine interface.

System status

This sub-menu can be used to display the interface inputs and outputs to machine controls.

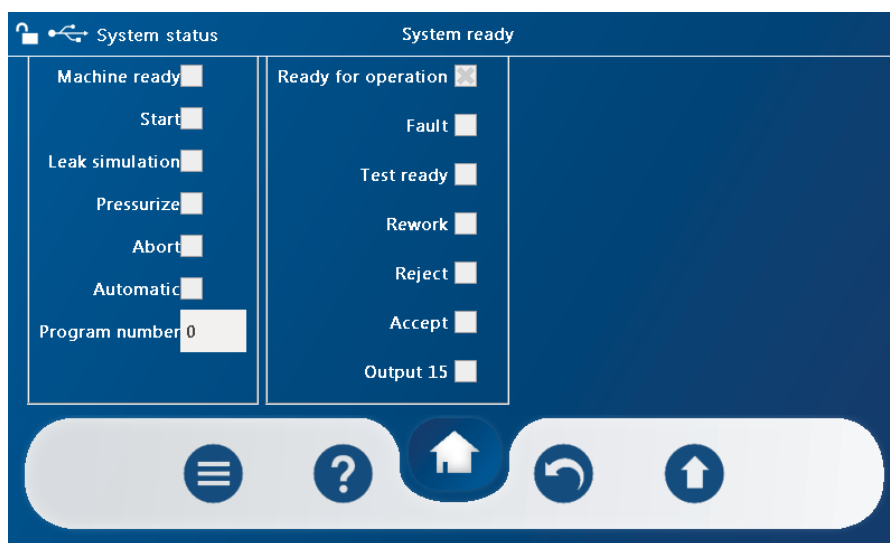



Figure 55: Dialog window System status settings

Signals that are present are displayed with an "x" in the check boxes.

All existing inputs and outputs are shown in the following order.

- Inputs of the machine interface of the test device
- Outputs of the machine interface of the test device

You can exit out of the menu by pressing the  or 

System parameters

This menu can be used to display all system parameter settings.



Figure 56: Dialog window System parameter settings

Page through the parameters by pressing



Under menu point **system data**, you can find all important data to configure the device.

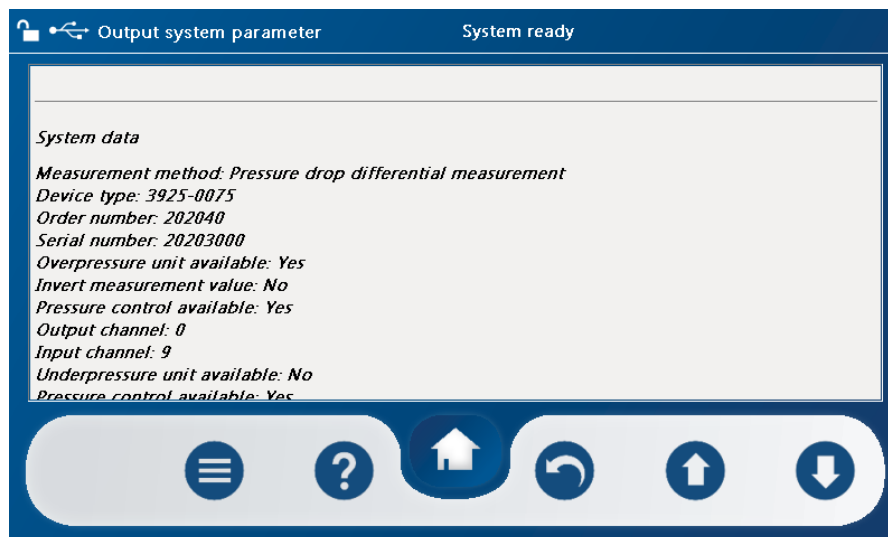

Figure 57: Dialog window System parameter settings System data

- Measurement method
- Device type
- Order number
- Serial number

Software version

Information about the device software version is found in this menu.

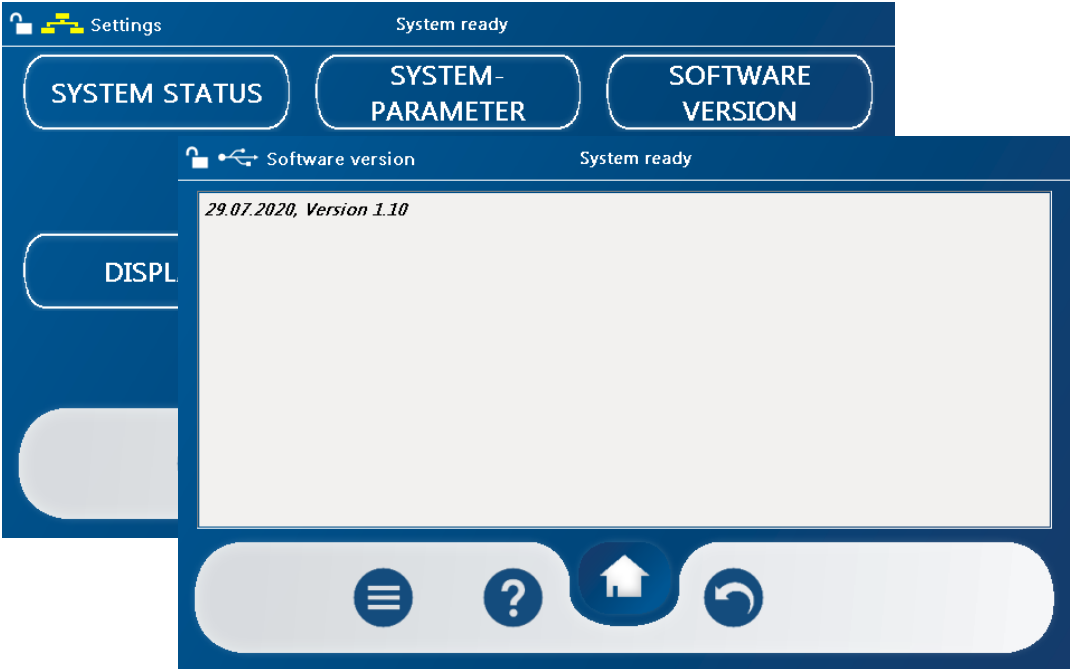

Figure 58: Dialog window Settings software version

Options

In the Settings/Options menu, you can set the machine interface, error limits for error 13 and the decimal places.

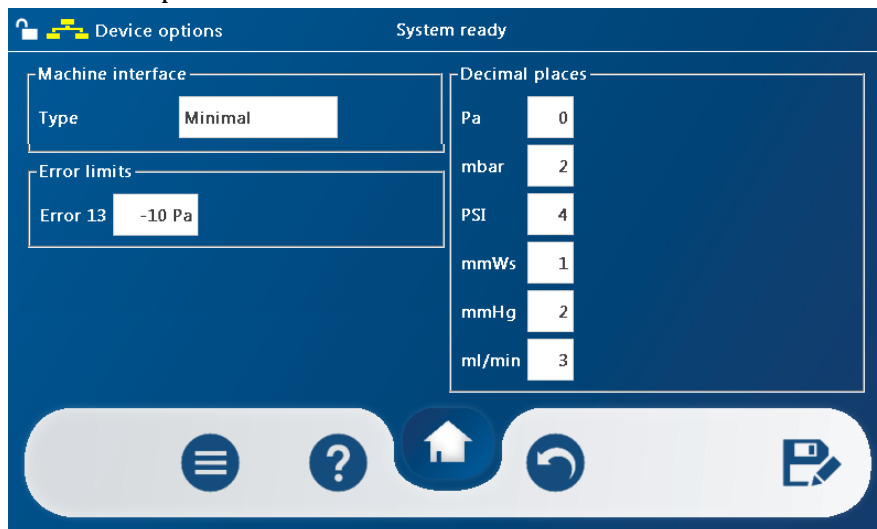

Figure 59: Dialog window Settings Options

Machine interface

Type

Select the machine interface mode by pressing the input field next to "Type". The following modes are available:

- Automatic (e.g. for control via PLC or manual control panel)
- Semi-automatic (e.g. for control via a start button)
- Minimal (e.g. for control via a proximity switch)
- Deactivated (interface is deactivated)

Error limits

Error 13

The error limit value can be changed by pressing the input field next to "Error 13".

	<p>ATTENTION! The error limit F13 is defined as -10 Pa by default. Any other value could result in faulty measurements. This value should therefore only be changed in consultation with HEMATECH PRÜFTECHNIK.</p>
---	---

Decimal places Pa

You can select the number of decimal places for the measurement unit **Pa** by pressing the input field next to "Pa". This value determines the number of decimal places the measurement unit is displayed.

The range is 0 ... 4

The default value is 0

Decimal places mbar

You can select the number of decimal places for the measurement unit mbar by pressing the input field next to "mbar". This value determines the number of decimal places the measurement unit is displayed.

The range is 0 ... 4

The default value is 0

Decimal places PSI

You can select the number of decimal places for the measurement unit PSI by pressing the input field next to "PSI". This value determines the number of decimal places the measurement unit is displayed.

The range is 0 ... 4

The default value is 4

Decimal places mmWS

You can select the number of decimal places for the measurement unit mmWS by pressing the input field next to "**mmWS**". This value determines the number of decimal places the measurement unit is displayed.

The range is 0 ... 4

The default value is 1

Decimal places mmHg

You can select the number of decimal places for the measurement unit mmWS by pressing the input field next to "**mmHg**". This value determines the number of decimal places the measurement unit is displayed.

The range is 0 ... 4



The default value is 2

Decimal place ml/mm

Select the measurement unit **ml/min** by pressing the input field next to "ml/mm". This value determines the number of decimal places the measurement unit is displayed.

The range is 0 ... 4

The default value is 1

Confirm with a push on  and accept the settings with 

Display

You can adjust display settings in this dialog window, such as brightness, language and in which menu the device should be started.

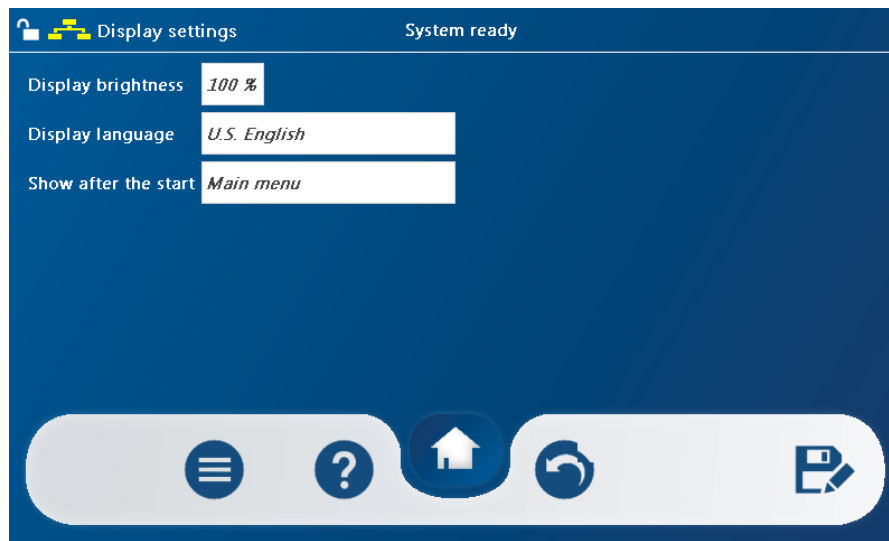

Figure 60: Dialog window *Display settings*

Display brightness



The display brightness can be changed by pressing the input field next to the "Display brightness", values from 2...100% are possible.

Display language

The user interface language can be set by pressing next to the "Display language" input field.

Display after the start

Pressing the input field next to "Display after start" you can define the start menu of the device

Confirm with a push on  and accept the settings with .

Date and time

This dialog window is used to set the date and time.

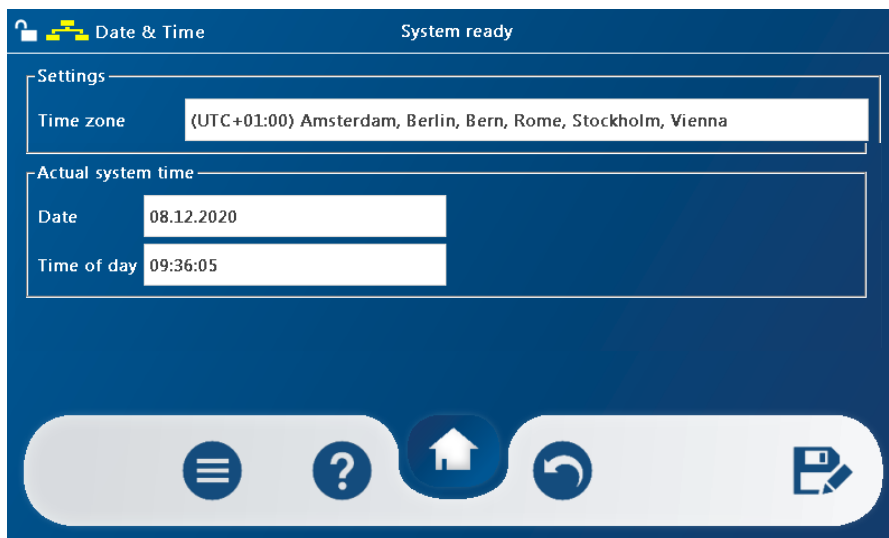

Figure 61: Dialog window Date & Time settings

Time zone



The time zone can be set by pressing the input field next to "Time zone".

Date

The date can be set by pressing the input field next to "Date".

Time

Set the time by pressing the input field next to "Time"

Confirm with a push on  and accept the settings with .

Software update

In this dialog window you can update the software of the system.

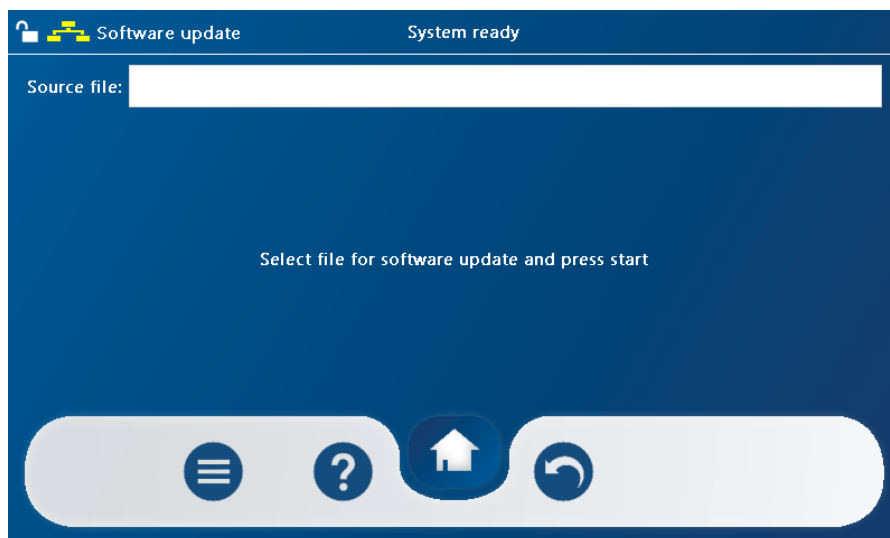

Figure 62: Dialog window Settings Software update

Source file

An update can be selected by pressing the "Source file" input field.



Note!

Before selecting the input field, plug in a USB stick to the USB port.

The USB stick has been detected when you see the symbol  in the menu bar

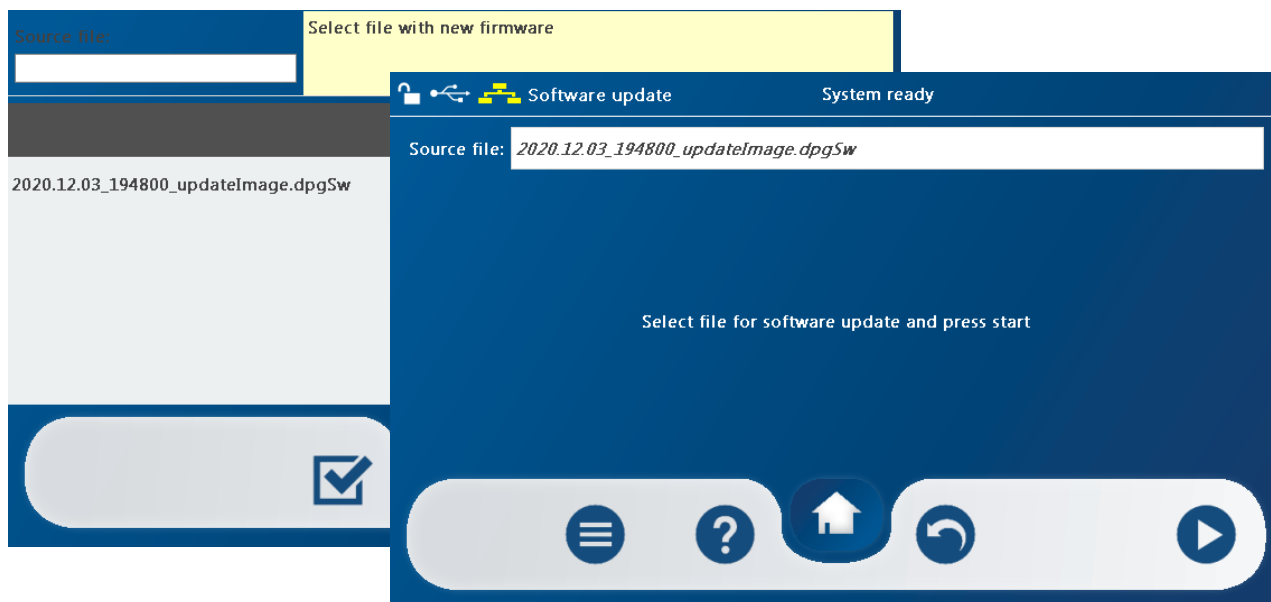



Figure 63: Dialog window Settings Software update - Execute update

Confirm by pressing  and do the update by pressing 

After the update a reboot will be carried out

Adjust pressure system

In this Dialog window, you can redetermine the settings for the pressure control (electronic pressure control).

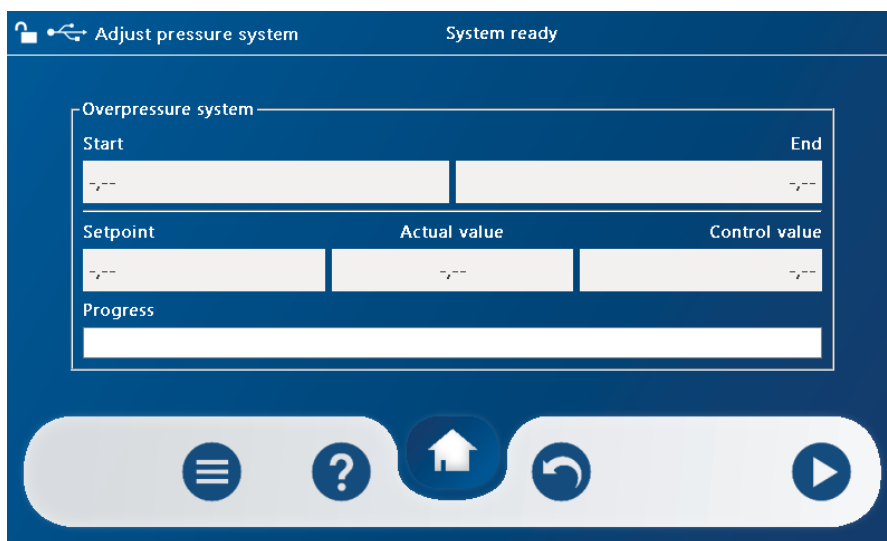



Figure 64: Dialog window adjust settings of pressure system

By pressing  you start to adjust the pressure system.

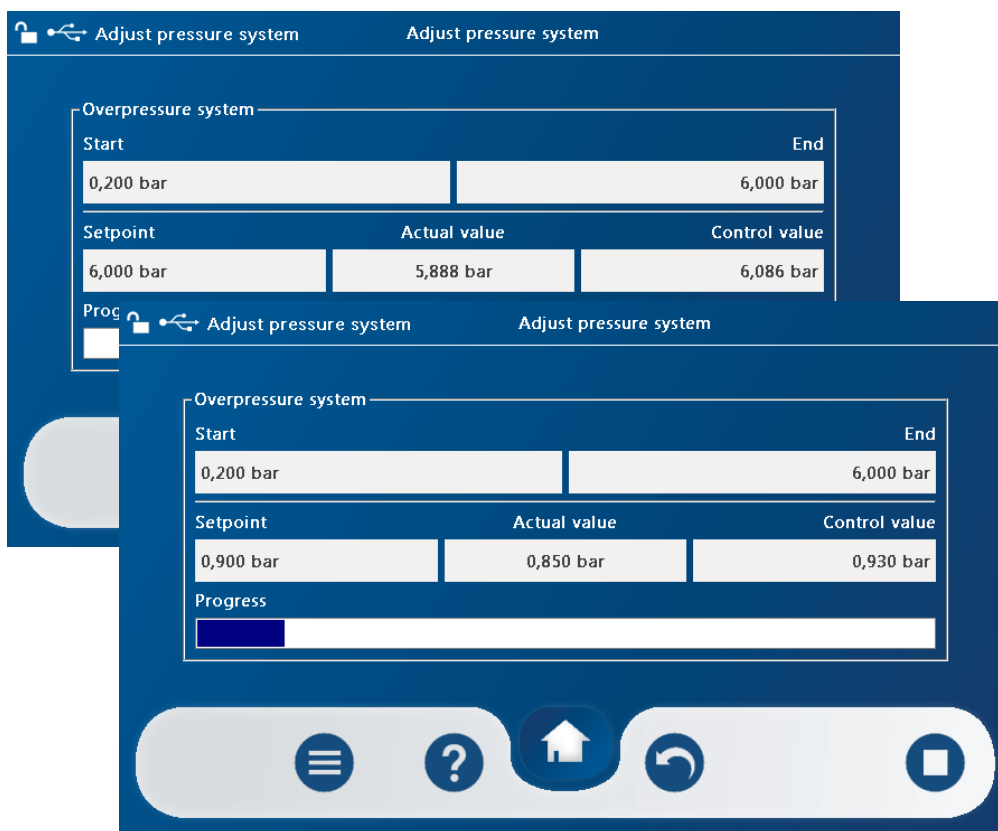

Figure 65: Dialog window adjust pressure system settings - Pressure adjustment

The device attempts to set the parameterised pressure. If the determination of the limit values is successful the pressure adjustment will start.

If pressure adjustment has been done successfully the following dialog window appears.



Figure 66: Dialog window Adjust pressure system settings - Pressure adjustment successful

Error in pressure detection

If there should be problems with the pressure detection, one of the following dialog windows will appear:

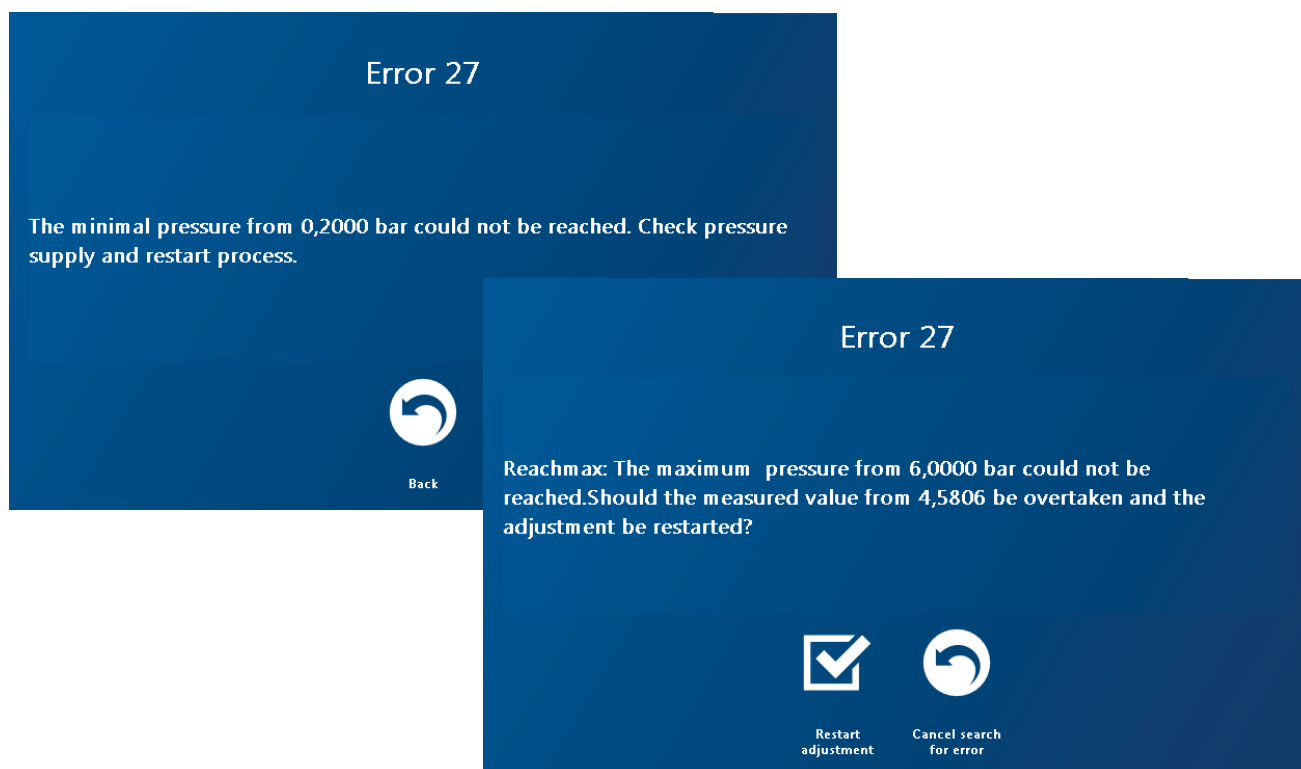

Figure 67: Dialog window Stabilise pressure system settings - Error 27

This dialog window gives two options to react to this error message:

- Abort to find the error. More information can be found in the troubleshooting table [Pressure system not adjustable](#)
- Restart the adjustment. The system determines the pressure table again up to the currently possible maximum pressure.

Data

In the **MAIN MENU** under **DATA**, you will find the dialog window **DATA**. In this menu you can view the operating data, available test programs and results as well as import and export data.

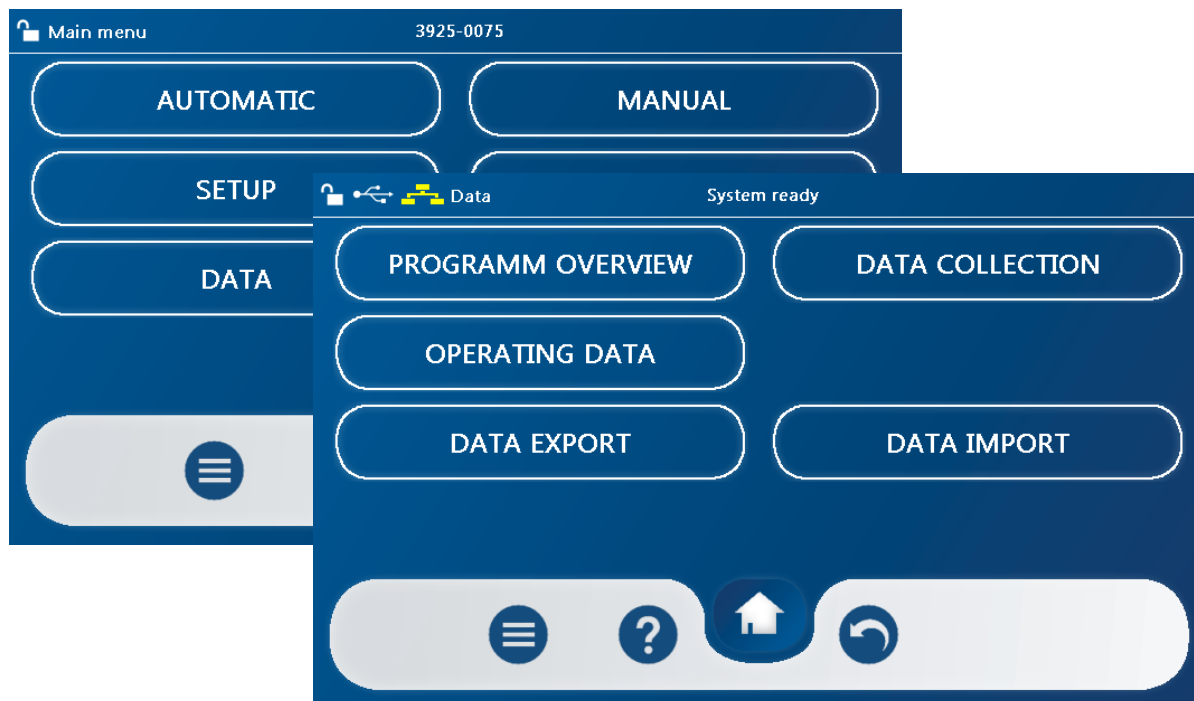



Figure 68: Dialog window data

View Program Status

In the dialog window program overview you can view all program numbers, which are already used, in the display. If a program has been selected it is displayed inverted.



Figure 69: Dialog window Data program overview

- You can display the selected program by pressing 
- Return to the program overview by pressing 

Data collection

In the dialog window data collection, you can display and/or export the measurement results and corresponding filling curves.

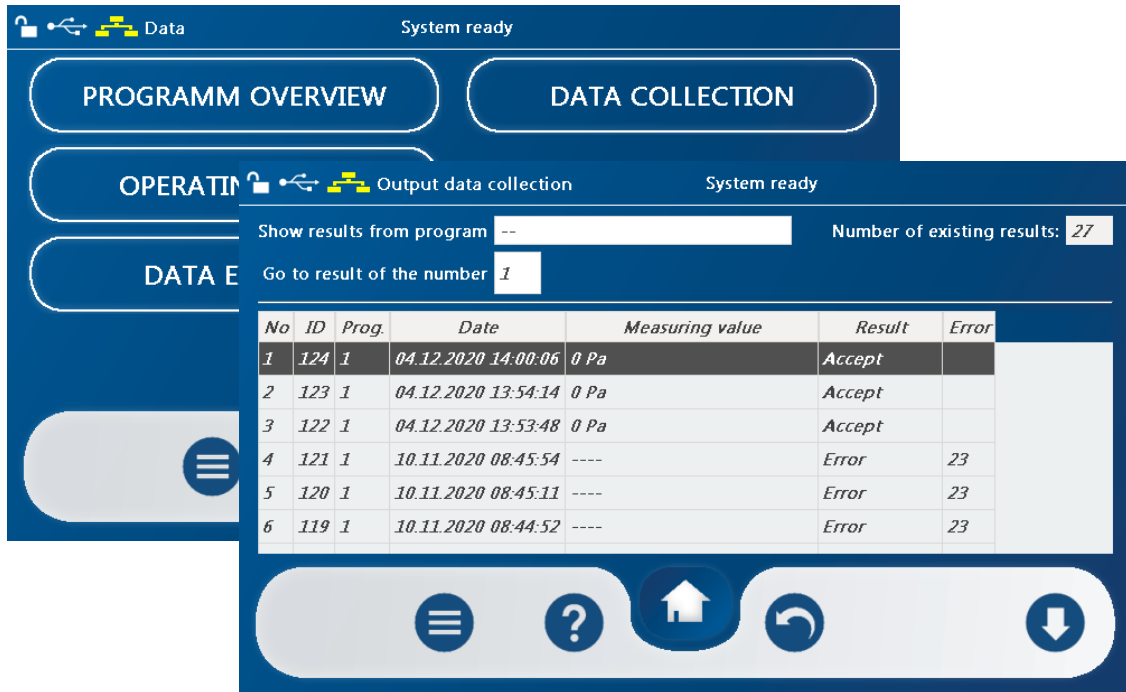



Figure 70: Dialog window Data collection

- Call up the context menu by pressing 

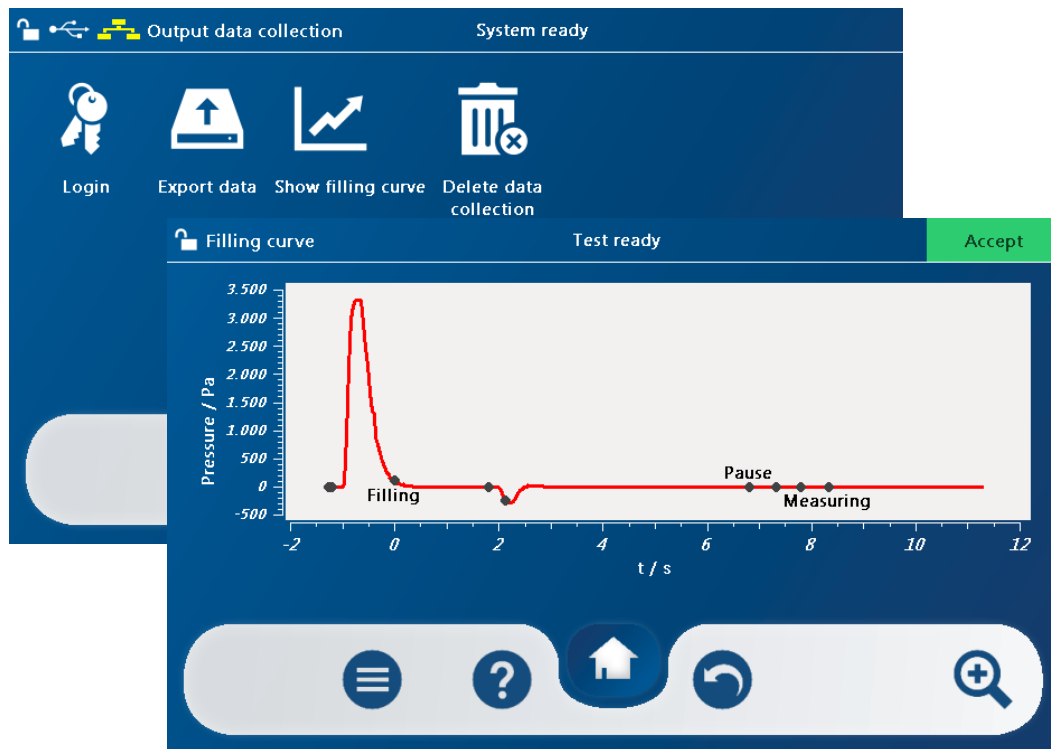



Figure 71: Dialog window Data results storage filling curve

- The filling curve of the previously selected results is shown by pressing 

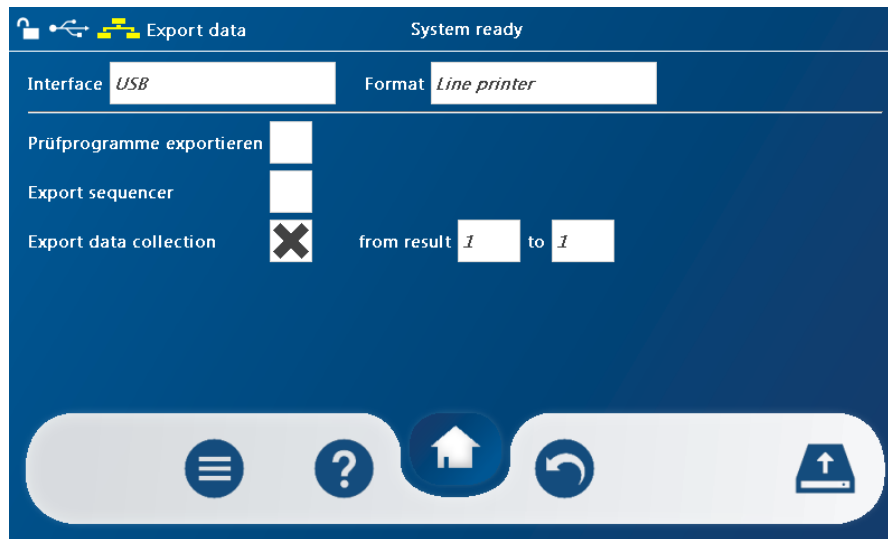

Figure 72: Dialog window Data - Data export

- Select the interface on which data output should be done by pressing the input field next to "Interface".
- Select the output format for results storage by pressing the input field next to "Format".
The following formats are possible via the **USB** interface:
 - File01
 - File02
 - Line printer
 - Filling curve (text)
 - Filling curve (image)
- The following formats are possible via the **Serial** interface:
 - File01
 - File02
 - Line printer
 - Filling curve (text)

NOTE!



A detailed list of possible interfaces and formats can be found in Appendix [Data output formats](#)

Operating data

You can see the total operating hours, error counter and the number of tests done using the test device and can display the number of different results depending on the program.

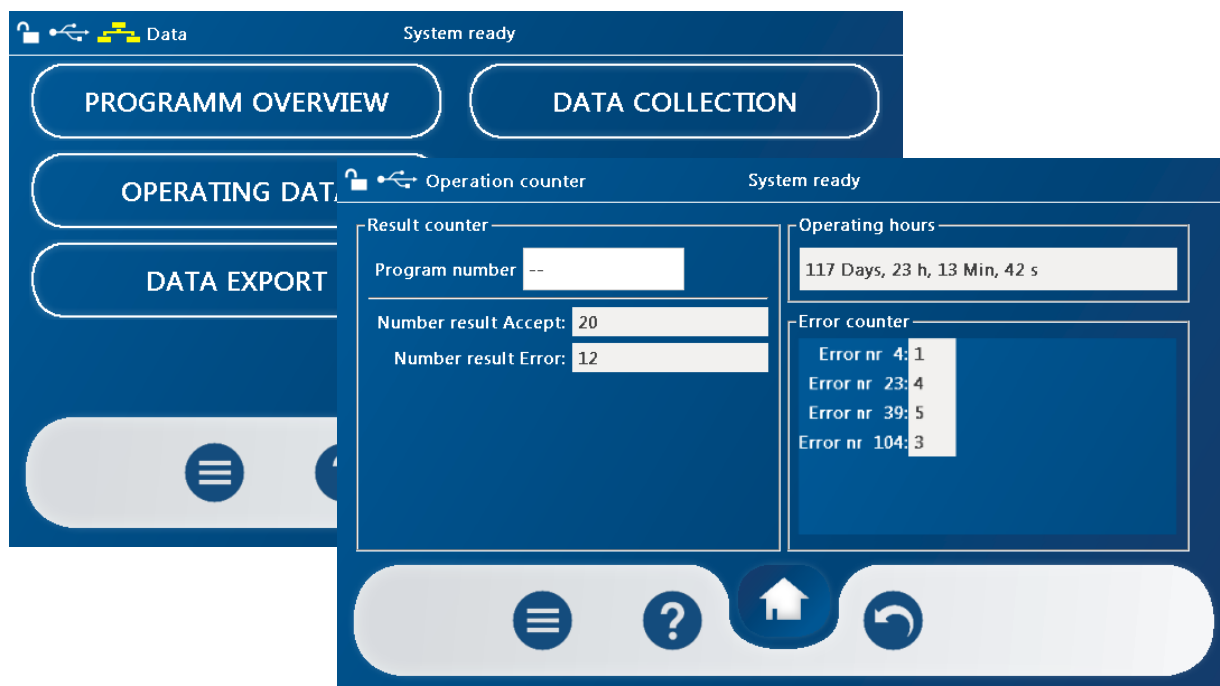



Figure 73: Dialog window Data Operating Data

- Via the context menu you have the option to delete counter
- Call up the context menu by pressing 

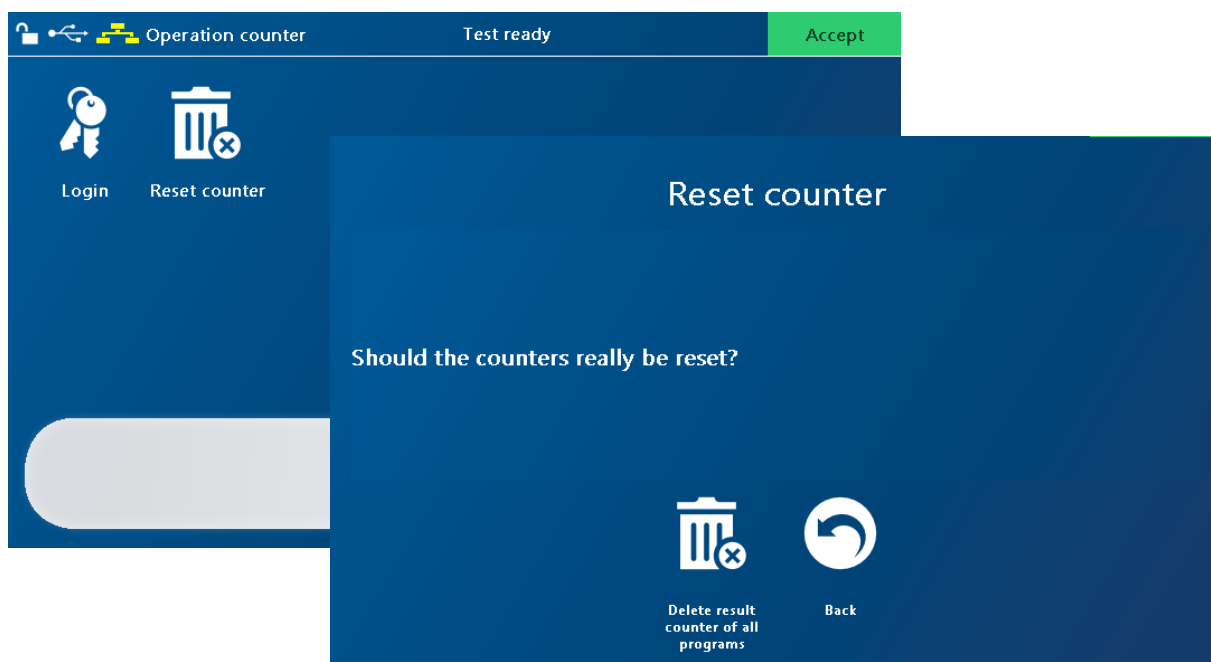



Figure 74: Dialog window, reset the Data operating data counter

- Select Reset counter by pressing 
- Delete the results row of all programs by pressing 

Data export

Test programs, sequencer settings, data collection and system parameters can be exported in this menu.



Figure 75: Dialog window Data - Data export

The Data export dialog window is available in several other menus. Depending on the menu from which data export is called, parameters to be saved are automatically selected. This selection can be adjusted at any time.

Data backup of test programs

Data backup of test programs can be done in 2 different formats.

Format data backup (only USB stick).

Files are stored on the USB stick in the following formats

Backup: DPG20100200 BACKUP 20201012094003.dpgDat

DPG: Leak Tester

20100200: Serial number of the device

BACKUP: Backup

20201012094003: Date and time

dpgDat: Data safety file

NOTE!



During export, all selected parameters are saved in a file. The name of the file can be changed on the PC. Mutated vowels may not be used in the file name (e.g. umlaut in German).

Format line printer:

Files are stored on the USB stick in the following formats

Line printer: DPG20100200 LPR.txt

DPG: Leak Tester

20100200: Serial number of the device

LPR: Line printer format

txt: Text file

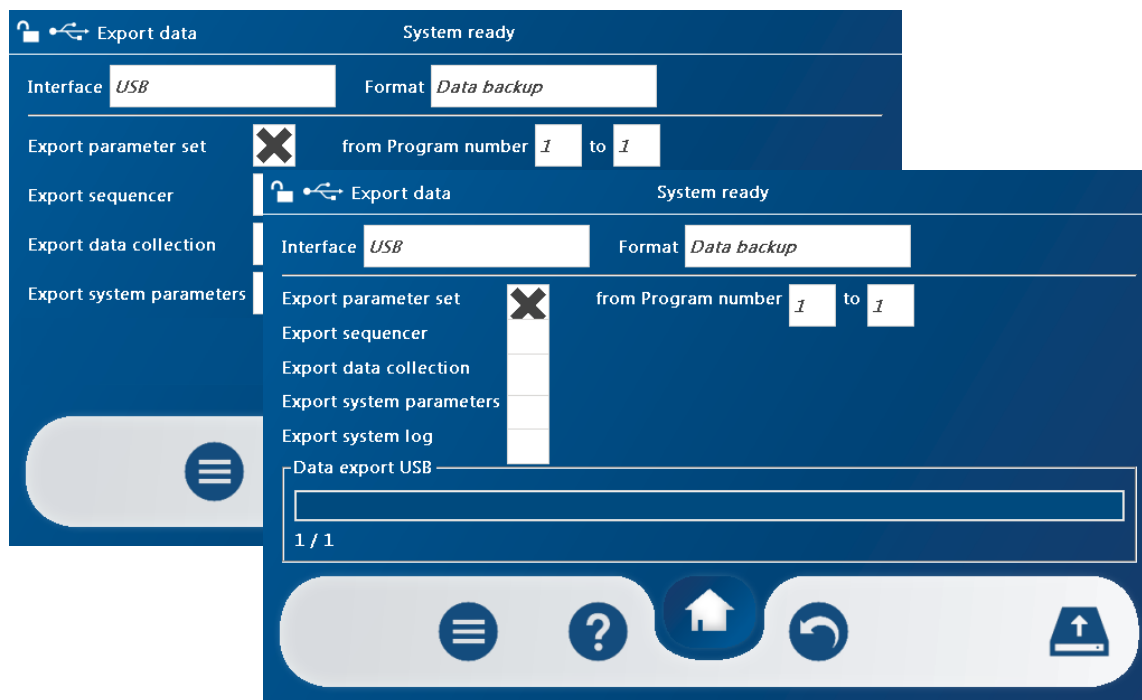



Figure 76: Dialog window Data - Data Export - Export data

- Select the interface which data output should be executed to by pressing the input field next to "Interface".
- Select the output format for the test program by pressing the input field next to "Format". The following formats are available for the **USB** interface:
 - Backup
 - Line printer
- Select the program number(s) to be exported
- Plug in the USB stick and start data export by pressing 
- Only remove the USB stick after the progress bar has disappeared

Data import:

Test programs, Sequencer and system parameters can be imported in this menu.

You can only import files with the extension

.dpgDat

These are data backup files.



Figure 77: Dialog window Data Data import

- Before selecting the input field, insert a USB stick into the front USB port

Before data import starts a query is made to check whether you really want to import the data and thereby overwrite existing data.

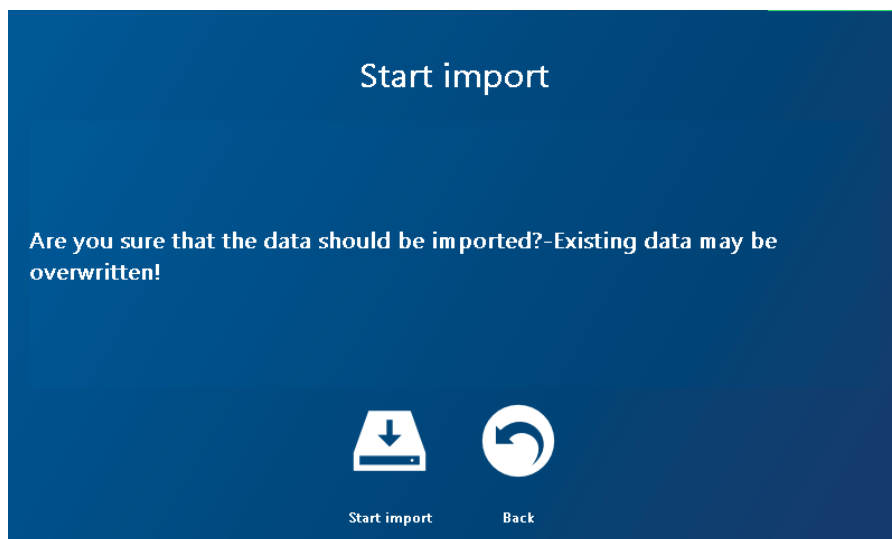

Figure 80: Dialog window Start data import

After starting import a progress bar is displayed.

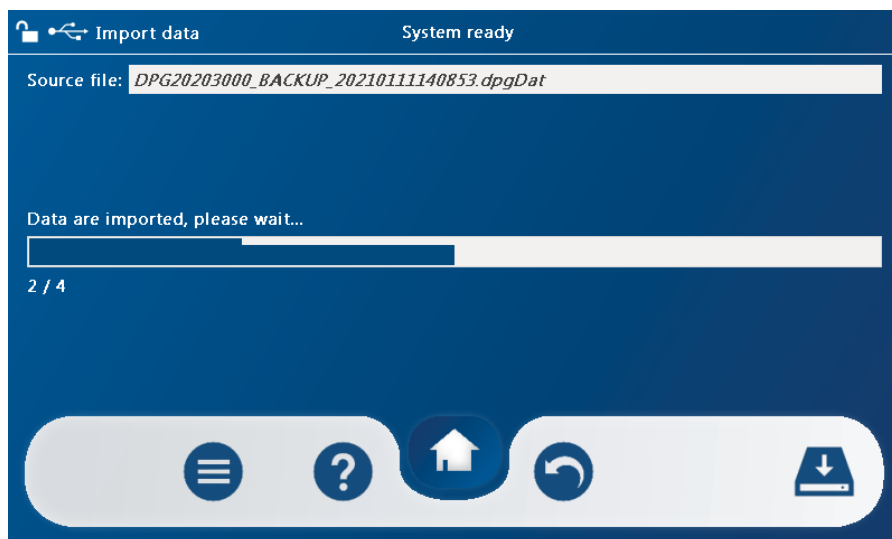

Figure 81: Dialog window Data - Data Import active

If data import was successful, the following dialog window is shown:

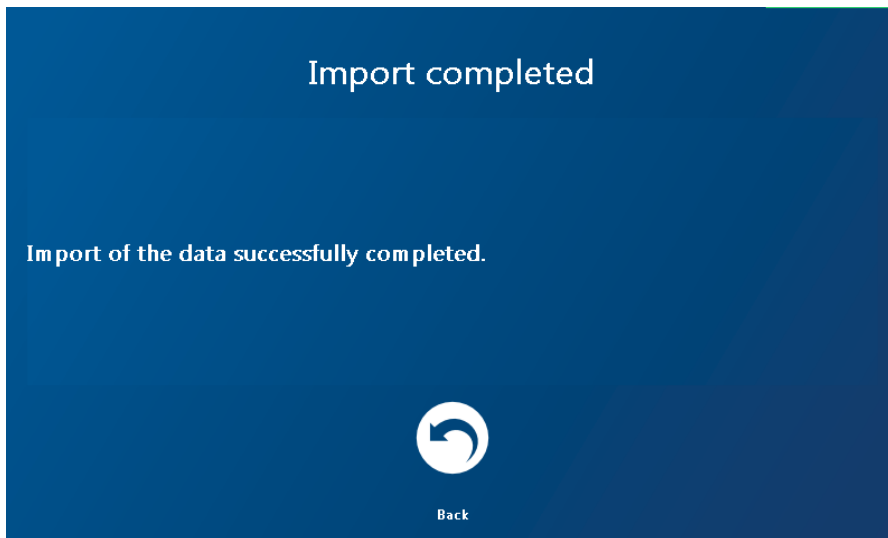

Figure 82: Dialog window Data - Data Import completed

Test and set up

Check the test device

To ensure that the leak tester 3925-0075 functions correctly and that you can rely on the measurement results, you should perform a self-test of the device before each use. This test should be performed without specimen, to achieve a reliable result.

Performing the self-test

- Make sure that the compressed air supply to the device is filtered and free of oil. Check the filter for safety
- Make sure that the supply air pressure is 1.5 bar higher than the adjusted test pressure, minimum and maximum values are specified in the pressure table on the back of the device.
- Make sure that the connections for specimen and reference volume are closed pressure-accept using the supplied closure caps.
- Set up the test program with the following test parameters:



Filling pressure	2.10 barg,	OFF
Underfilling pressure	1.90 barg	
Test pressure	2.00 barg	
Filling time	3.0 sec	
Underfilling time	0.3 sec	
Stabilisation time	3.0 sec	
Pause time	1.0 sec	
Tare time	0.5 sec	
Measuring time	3.0 sec	
Venting time	1.0 sec	OFF
Pressure tolerance	1.0 %	
Measuring value unit	Pascal	
Rework limit value	10.0 Pa	ON
Leak	50.0 Pa	ON
Series fault from	5	

- Save the program parameter by pressing 

or

- Return the keyswitch to the vertical position 

If the pressure values cannot be adjusted because the tester has a lower pressure range, use the maximum possible test pressure for self-testing.

- Press the  key to jump to the MAIN MENU.
- Choose into the menu Manual → Test menu
- Select test program in the input field and confirm by pressing 

 Press "Play" key to start the test without leak simulation.

With an intact device the measuring values should not deviate for more as ± 4 Pa when repeating the measurement.

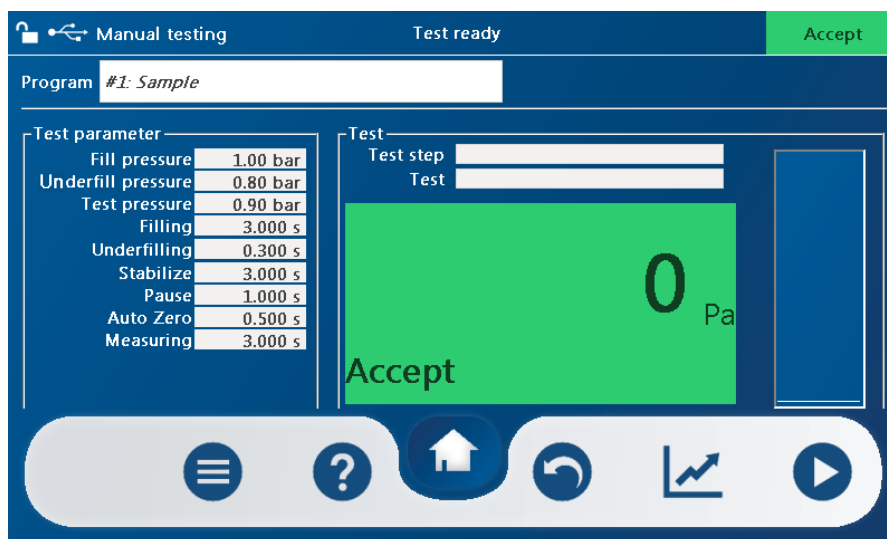

Figure 83: Dialog window Manual testing Result Accept

After a successful measurement "Accept" can be seen in the dialog window

Performing self-test with leak

When performing a self-test without specimen but with a leak of 2.5ml/min and a test pressure of 1 barg for a measuring time of 3 s, the leak tester should indicate a result of approx. 1700 Pa.

NOTE!



The measurement result may show deviations to the expected measurement value depending on additional hose volume of the test leak connection.

Setting up the device for specimen

Testing with filling pressure

When testing under filling pressure (shock filling) set the filling pressure approx. 0.2 barg or 10% higher than the test pressure. However, the exact filling pressure can only be determined with a specimen connected. To do so:

- Connect a fully leak Accept specimen to the specimen connection on the back of the tester, position 29

As a rule of thumb for determining the test times, the filling time and stabilisation time together must cover approx. $2/3$ and the measuring time approx. $1/3$ of the test cycle.

Stabilisation time and filling time must be considered as independent functions:

- The filling time may set a trend for the measurement.
- The stabilisation time stabilises the measurement and thus the repetition accuracy.

Example trend measurement

After the filling time has been set to 3 seconds and the stabilisation time to 5 seconds, the displayed reading moves with constant speed to 50 Pa over a measuring time of 5 seconds.

When extending the filling time, the trend will be reduced e.g. to 5 ... 10 Pa at the same measurement time.

If the filling time is too long, the sign of the trend measurement will change; the reading moves below 0 Pa to the negative range.

Once you have determined the optimal filling time, you can exactly adjust the stabilisation time. You can carry on reducing the stabilisation time, as long as the measuring values remain repeatable with sufficient accuracy.

This measuring time depends on the leak rate to be measured and the setting of the limit contacts. This setting is best made using a specimen with boundary leak.

Testing without filling pressure

For testing without filling pressure (shock filling) you must consider the filling and stabilisation times as connected times.

You must dimension the filling and compensation time in such a way that, after the compensation time has elapsed, the measured value display neither jumps nor moves by more than 5 Pa within 3 seconds of measuring time.

NOTE!

The cycle time can be reduced by shortening the filling or the stabilisation time and to run a so-called trend measurement.

Example:

With a Accept specimen the measuring value display moves for 10 Pa and with a specimen with boudary leak it moves up to 20 Pa.

The measuring time depends on the leak rate to be measured and the setting of the limit contacts. This setting is best be made with a specimen with boudary leak.

Maintenance

Maintenance of the device should be performed at regular intervals, depending on the utilisation level (at least once per year). Maintenance of the device should be included in the company internal inspection intervals.

Maintenance contract

For devices manufactured by us you can, if desired, enter into a maintenance contract with HeMaTech Prüftechnik for regular inspections and preventive maintenance. We will inform you about the terms and conditions on request.

Maintenance plan

The following table shows the maintenance work required to maintain the tester in operable condition for normal operation.

Maintenance work	Schedule	Info
Check the service unit	Weekly	Check filter cartridges and replace if necessary
Performing the self-test	At every change of shift or specimen	See Section Perform calibration test
Perform a self-test with leak or master specimen with leak	At least once a month	See Section Do a calibration test with a test leak
Clean the shut-off valve	Every six months and annually in case of certification	Q1
Certification and calibration	Annually	By HeMaTech Prüftechnik GmbH & Co. KG

Errors, Causes and Remedy

The test device monitors valves, measuring transducers, specimen and the function sequence. As soon as an error occurs, it is shown in the measurement display, in automatic mode a potential-free contact switches to "Error". A visual error message appears on the touch display.

Acknowledging error messages

Depending on the operation mode the error messages must be acknowledged in different ways:

Operation mode manual

- After the error has been fixed, confirm the error by pressing  and return to the "Manual test" dialog window

or

- Press the  key to repeat the selected function, after the error has been corrected.

Automatic mode

- After the error has been fixed, remove the AUTOMATIC (X21/6) signal and replace it to acknowledge the error.

Semi-automatic mode

- After the error is fixed, confirm the error by pressing  and return to the dialog window

or

- Apply START signal to interface (X21/2)

Minimal mode

- After the error has been fixed, confirm the error by pressing  and return to the Dialog window

or

- Apply START signal to interface (X21/2)

Trouble Shooting Chart

The following chart lists all error messages, which may be displayed during operation of the leak tester. Each error message has a number, which gives you the possibility to easily locate the possible cause and the corresponding remedial action in the chart. Should any faults not be listed in the chart, please do not hesitate to contact the customer service of HeMaTech Prüftechnik directly.

All activities in the column *Remedy*, which are marked with *, must only be performed by trained expert personnel.

No.	Message	Possible cause	Remedy
0		The tester is not correctly controlled	Change the control, see also chapter signal exchange with machine control
1	No operating pressure	No air supply on tester	Switch on the air supply and check the air hose
2	Not used		
3	Program parameters does not exist	No test parameters in selected program	Enter test parameters in menu Setup/Test programs
4	Differential pressure converter defective	Differential pressure converter defective	Contact customer service
		Zero point of differential pressure converter out of adjustment	Readjust the differential pressure measuring converter*
		Output board defective X18	Replace the output board*
		Differential pressure converter full of oil, water, ...	Clean and adjust the measuring circuit*
		Power supply unit defective	Check the voltage of the power supply unit*
		Breakage in connecting cable to differential pressure converter	Check connecting cable*
		Shut-off valve defective	Replace the middle section of the shut-off valve*
5	Not used		
6	Not used		
7	Not used		
8	Not used		
9	Not used		
10	Gross leak (major leak) Reference volume	Differential pressure converter extremely deflects to minus during tare time	Check test parameters (filling time too long or filling pressure too high)
		Reference volume leak	Check reference volume connection for leaks and clean the shut-off valve*
		Shut-off valve defective	Replace middle section of shut-off valve or diaphragm*
		Diaphragm of shut-off valve defective	Replace middle section of shut-off valve or diaphragm*

No.	Message	Possible cause	Remedy
11	Not used		
12	Not used		
13	Fine leak Reference volume	Differential pressure converter slightly deflects to minus during tare time	Check test parameters (filling time too long or filling pressure too high)
		Reference volume leak	Check reference volume connection for leaks, clean the shut-off valve*
		Fixture reduces test volume	Check device for movement during measuring time
		Differential pressure converter full of oil, water, etc.	Clean and readjust the measuring circuit*
		Shut-off valve defective	Replace the middle section of the shut-off valve*
14	Series fault	Preset series fault counter exceeded	UnAccept parts only
		Sealing of device defective	Replace the sealing of the device
		Leak tester unAccept	Performing the self-test
15	not used		
16	not used		
17	Overrun of the absolute pressure converter	Pressure system outside tolerance	Re determine stabilisation of the pressure system in menu Settings\ Pressure system
18	Limit contact for Leak cannot be exceeded	Test pressure too low	Increase test pressure, change limit contact
19	Pressure increase after closing the shut-off valve	Pressure increase in specimen	Check the fixture for any movements
20	Apex of filling time not reached	Incorrect specimen	Check the specimen
		Supply line worn	Check the supply line
21	Not used		
22	Not used		
23	Filling pressure after expiration of filling time too low	Supply pressure too low	Check the network pressure (see chapter <i>Connecting the test medium hose</i>)
		Coarse leak on specimen	Check the specimen
		Pressure system outside tolerance	Re determine stabilisation of the pressure system in menu Settings\ Pressure system
		Filling time too short	Check the filling time
24	Filling pressure after expiration of filling time too high	Pressure system outside tolerance	Pressure system in menu 6. Settings/3. Pressure system
25	Filling pressure after expiration of stabilisation time too low	Network pressure too low, coarse leak on specimen,	Check the network pressure (see chapter <i>Connecting the test medium</i>)
		Pressure system outside tolerance	Pressure system in menu 6. Settings/3. Pressure system

No.	Message	Possible cause	Remedy
		Stabilisation time too short	Check the stabilisation time
26	Filling pressure too high after expiration of stabilisation time	Pressure system out of tolerance	Pressure system in menu 6. Settings/3. Pressure system
		Shut-off valve defective	Replace the middle section of the shut-off valve*
27	Pressure system not adjustable	Network pressure too low	Check the network pressure (see chapter <i>Connecting the test medium</i>)
		Test medium connection not connected	Connect the test medium connection
		Pressure system defective	Inform the customer service
		Proportional control valve defective	Replace proportional control valve *
28	Rated pressure out of range	Network pressure too low during pressure determination	Pressure system in menu 6. Settings/3. Pressure system
29	Not used		
30	Not used		
31	Not used		
32	Not used		
33	Not used		
34	Not used		
35	Not used		
36	Not used		
37	Test pressure in sequence too low	Coarse leak (major leak) on specimen, (under pressure), otherwise like error 25	
38	Test pressure in sequence too high	Coarse leak (major leak) on specimen, (under vacuum), otherwise like error 26	
39	No reference curve	Generate a reference curve	
40	No test step activated	Activate test step in sequencer	
50	The pressure system is not adjusted	Adjust pressure system not completed	Adjust pressure system. Settings → Adjust pressure system → Start

Signal Exchange with Machine Control

Signal description via parallel interface (machine control)

Automatic	Signal from the machine control (PLC)
Ready for operation	Signal to machine control (PLC)
Machine ready	Signal from the machine control (PLC)
Program number	Signal from the machine control (PLC)
Ready for test	Signal to machine control (PLC)
Test result	Signal to machine control (PLC)
Start (measurement)	Signal from the machine control (PLC)
Abort	Signal from the machine control (PLC)
Fault	Signal to machine control (PLC)

Automatic must be a permanent signal, which is already applied when switching on the test device.

Ready for operation is submitted by the test device after switching on.

Machine ready is applied after the signal **Automatic** and **Ready for operation** and removed when applying the signal **Start**. Together with the signal **machine ready** the applied **program number** is read.

Program number may be permanent signals.

Ready for testing is set after the tester has read in the **program number**.

Start should be an approx. 1 second pulse.

Test result (UT, OK or LT) remains valid, until a new signal Machine ready is applied again.

Abort

If the **Abort** signal is set during measurement then the running test is aborted and the **Ready for operation** signal is set.

The **machine ready** signal must be reset for subsequent tests.

The **error** is reset by removing and replacing the **automatic** signal.

Automatic operation

The **Automatic** signal must be set, then the **machine ready** signal occurs, the output signal **Ready for testing** is set and the selected program number is read in. Simultaneously the **Ready for operation** and **Test result** signals are reset. Now the measurement can be triggered with the signal **Start** (pulse of approx. 1 second). Remove the signal **Machine ready**. Once the measurement is finished, the **test result** (leak Accept, leak or rework) is submitted and the output **Ready for operation** is set.

NOTE!



The signal **Machine ready** must be set before each measurement, whereby the signal for program selection may always be present.

Flow chart of automatic operation

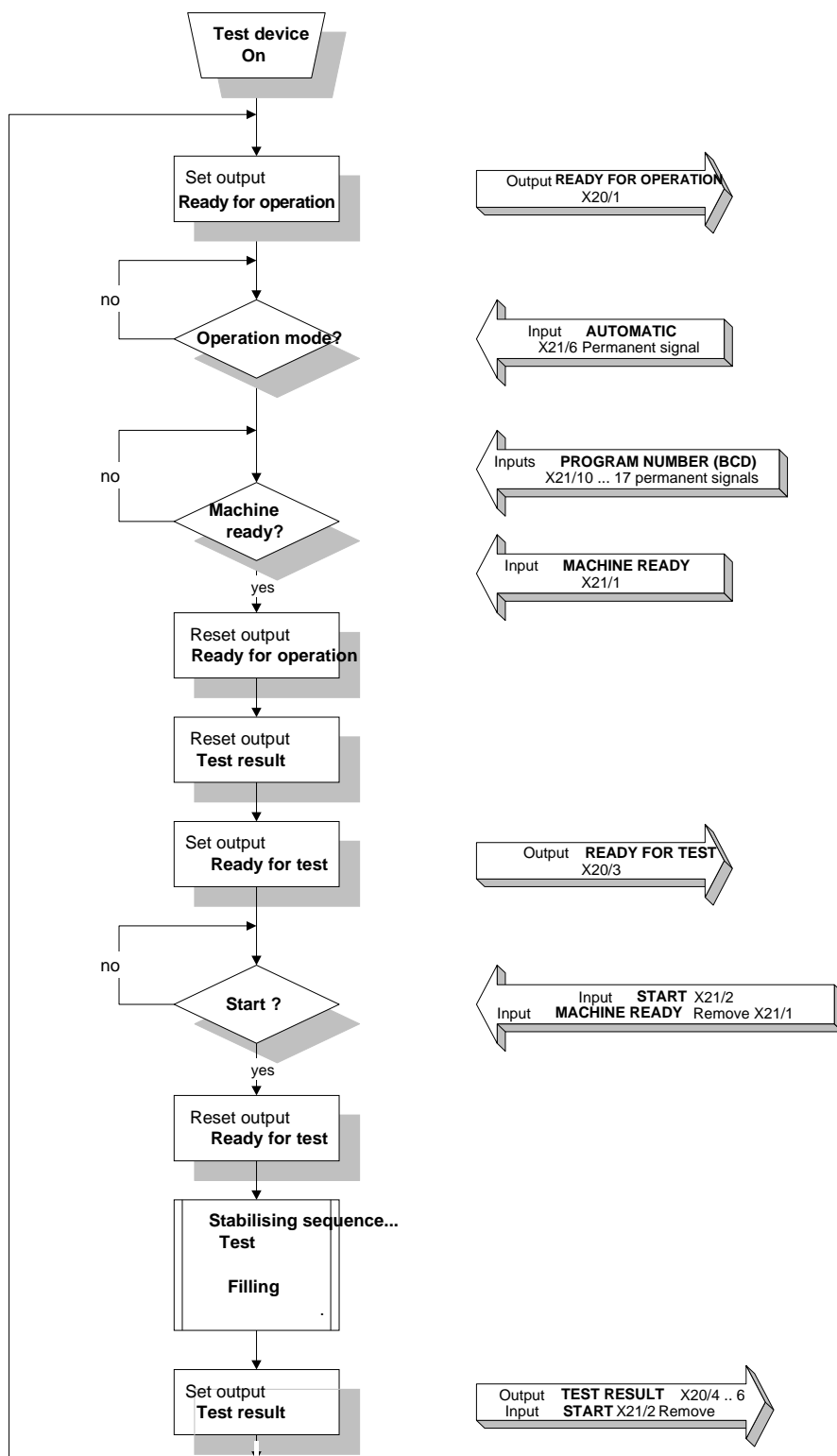

Automatic operation in a time-way diagram

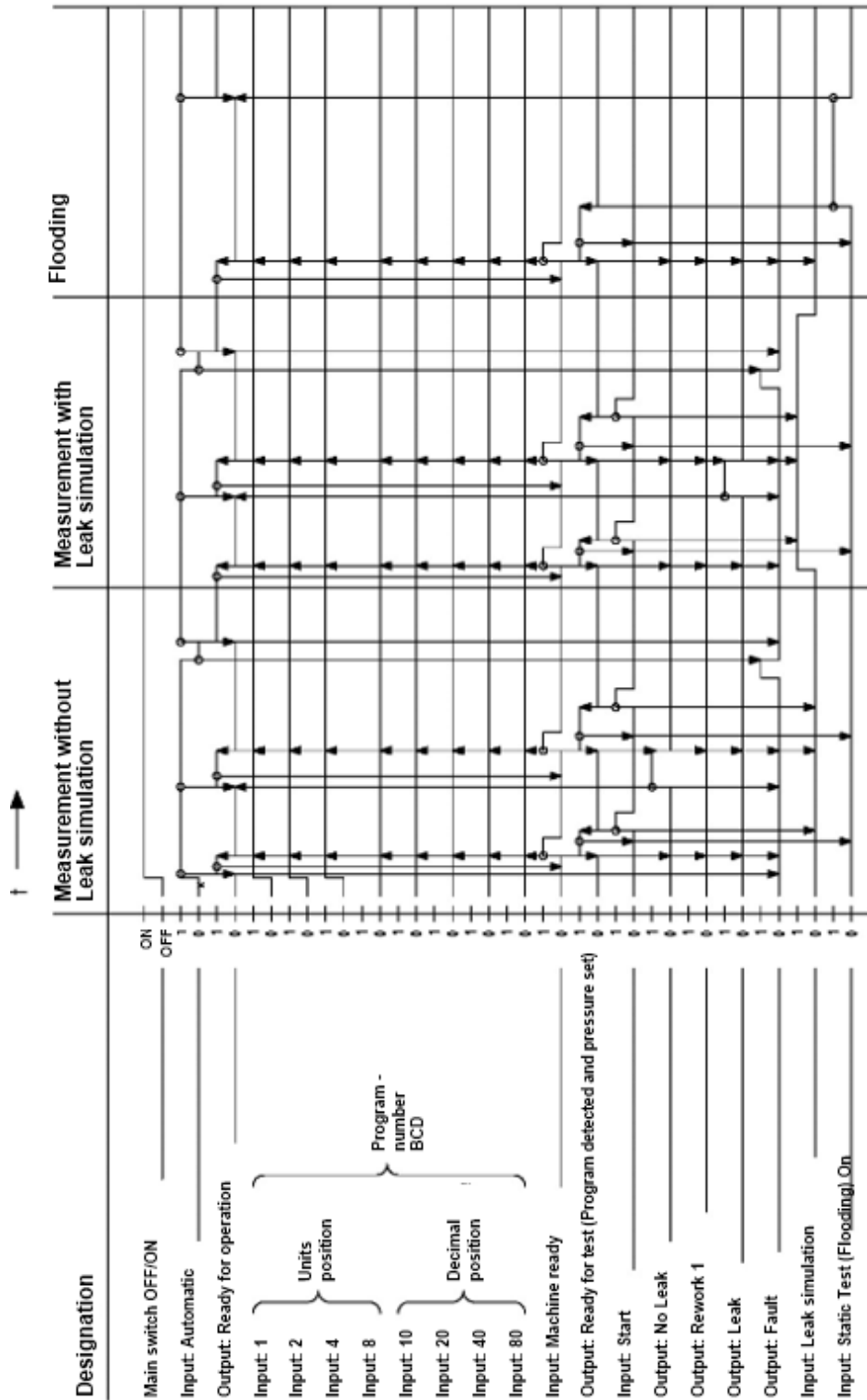

Semi-automatic operation

The signals **Automatic**, **Machine ready** and **Ready for test** are not used in this operation mode. The program numbers are entered or changed via the keypad.

When the tester is switched on, the output **Ready for operation** is set.

Now the measurement can be triggered with the signal **Start** (pulse of approx. 1 second), the test result is deleted.

Once the measurement is finished, the test result (leak Accept, Leak or rework) is submitted and the output **Ready for operation** is set.

Semi-automatic in flow diagram

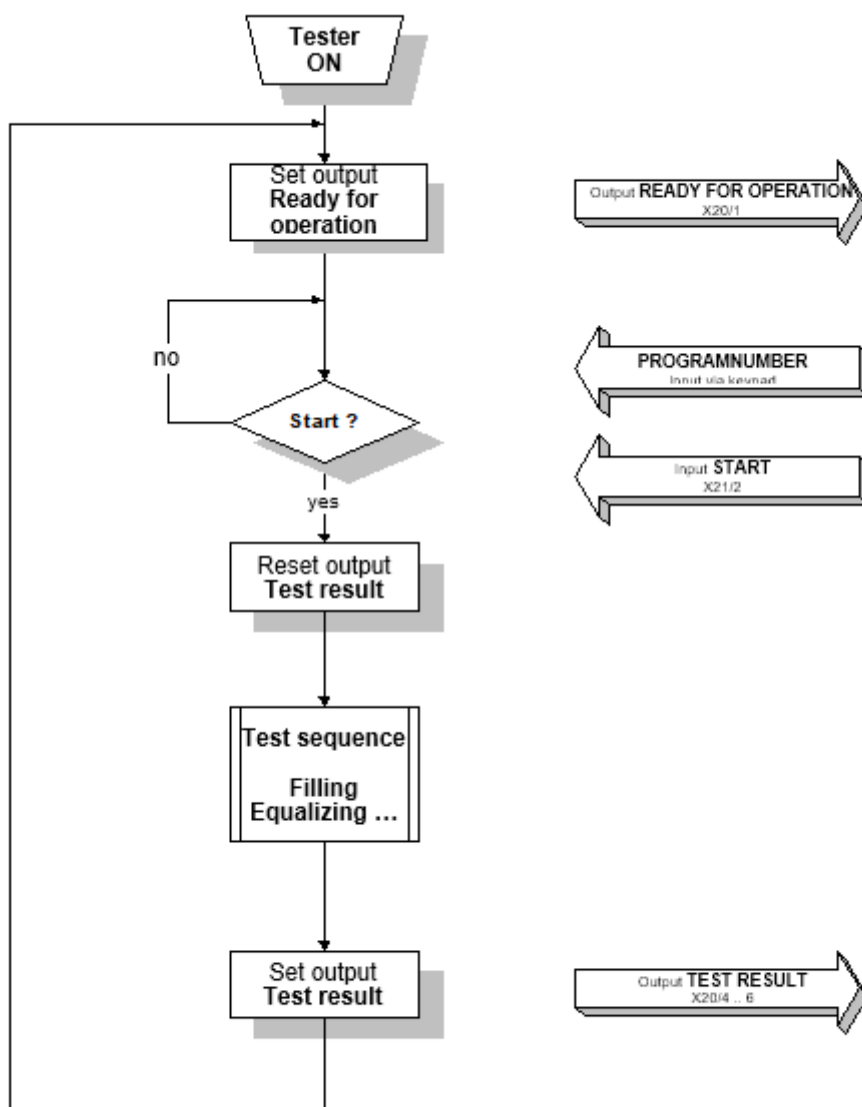

Semi-automatic operation in a time-way diagram

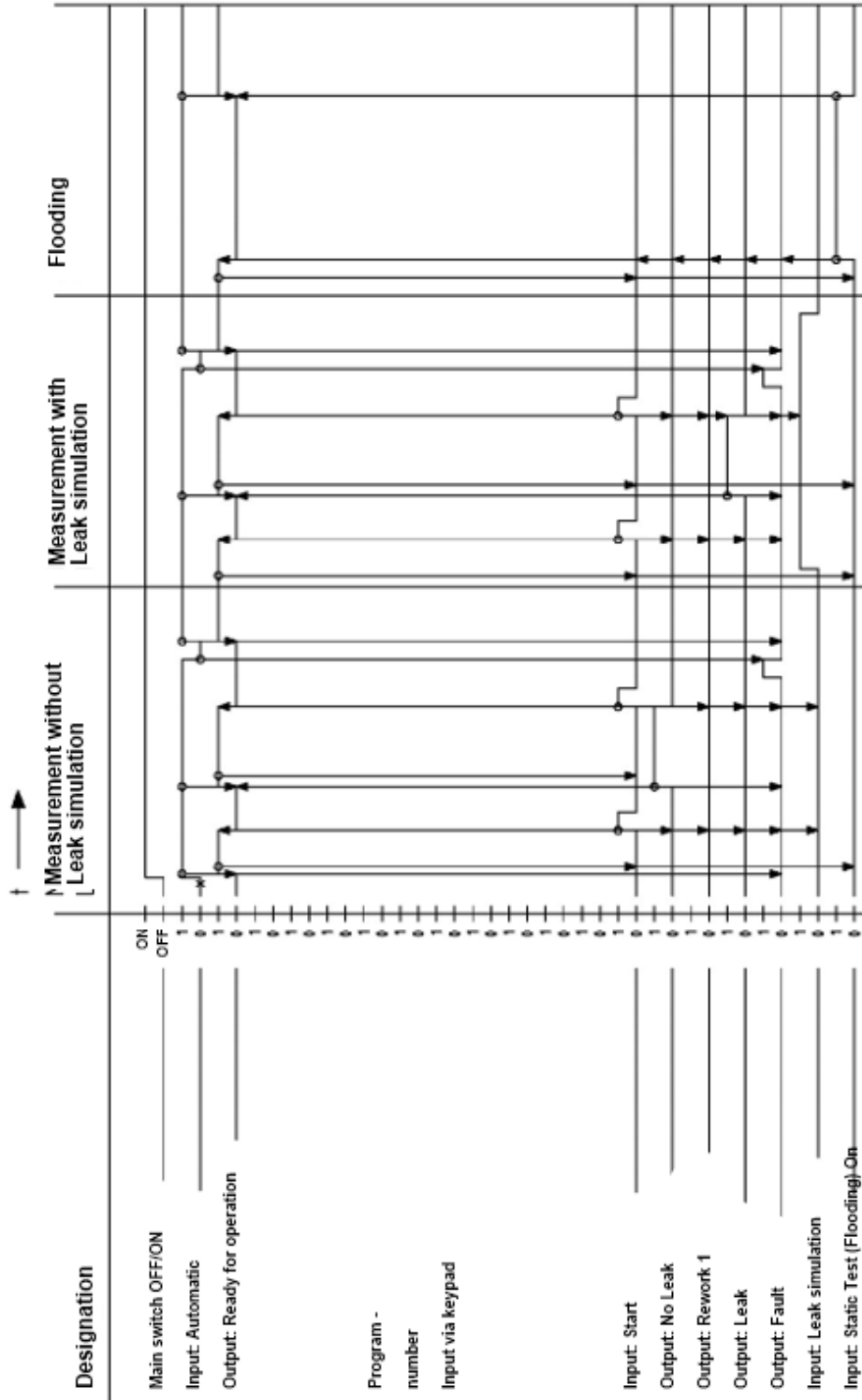

The input " Start" should be a pulse with a length of approx. 1 seconds.

*Entry point after removing the signal " Abort" . This signal deletes all outputs and interrupts the measuring process at any point (only in automatic mode). The specimen is vented (e.g. for emergency stop).

Minimal operation

The signals **Automatic**, **Machine ready** and **Ready for test** are not used in this operation mode.

The program numbers are read in at the start as binary code.

When the tester is switched on, the output **Ready for operation** is set.

Now the measurement can be triggered with the signal **Start** (pulse of approx. 1 second), the test result is deleted.

Once the measurement is finished, the test result (leak Accept, Leak or rework) is submitted and the output **Ready for operation** is set.

Flow chart for minimal operation

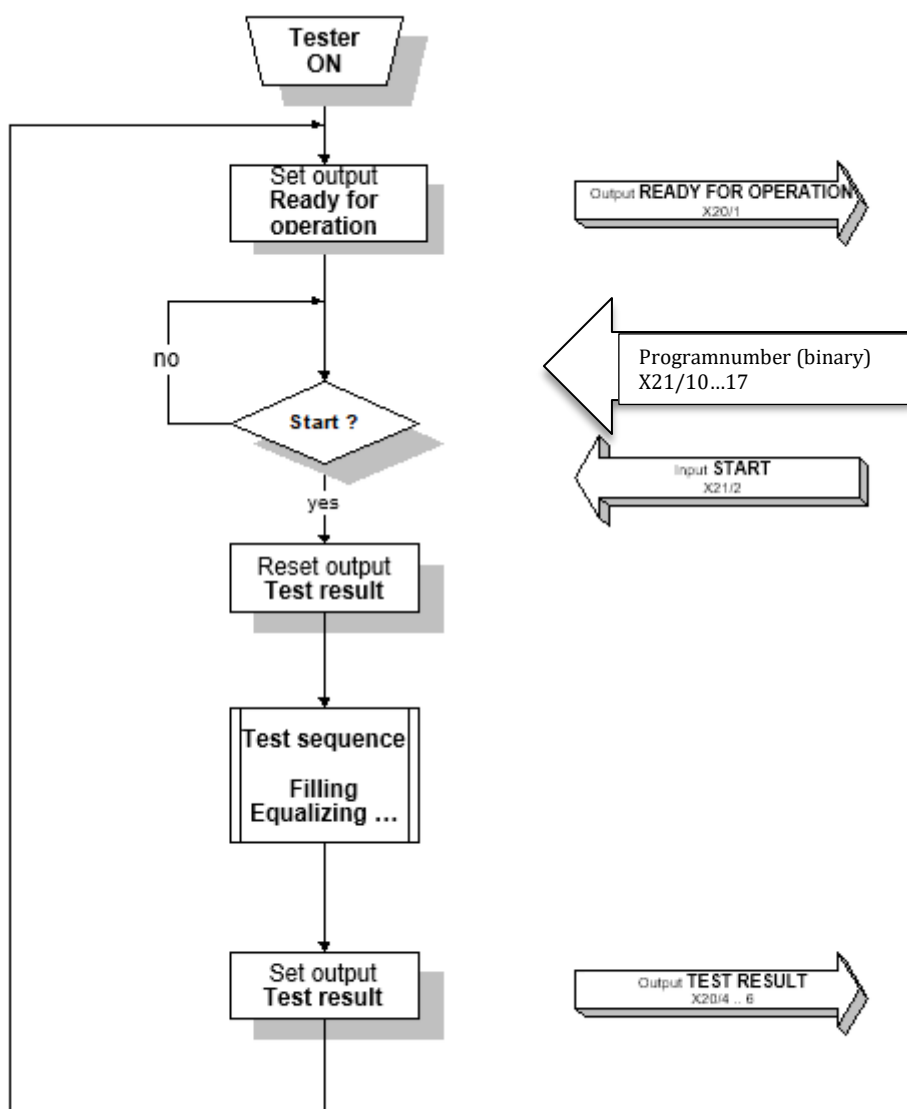

Minimal operation in a time-way diagram

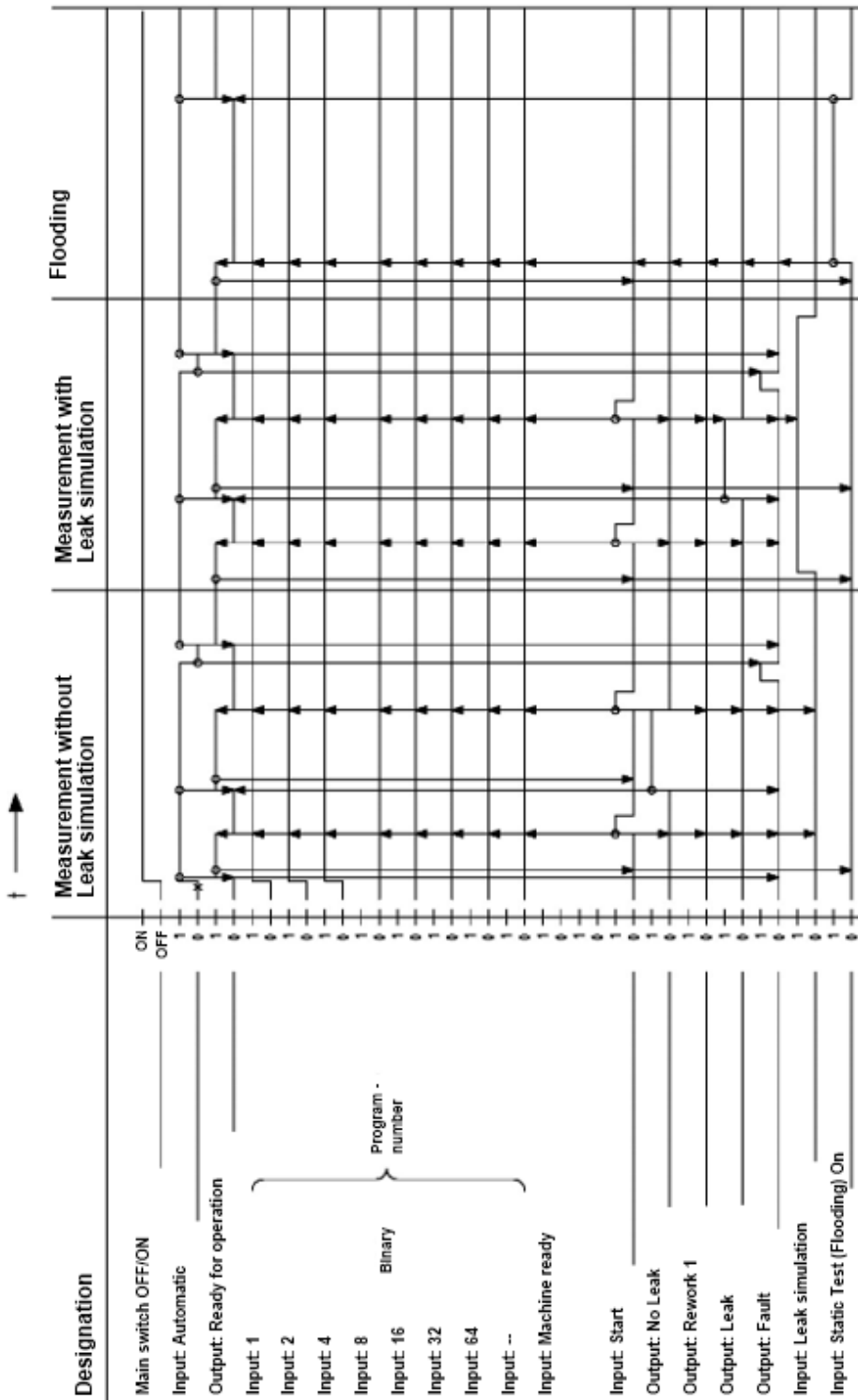

(Program number 7 is displayed)

The input " Start" should be a pulse with a length of approx. 1 seconds.

*Entry point after removing the signal " Abort" . This signal deletes all outputs and interrupts the measuring process at any point (only in automatic mode). The specimen is vented (e.g. for emergency stop).

Sample printouts

This section shows some sample printouts of the tester via serial interface to a printer or PC.

Protocol printout

HeMaTech Prüftechnik, Siemensstraße 7, 71409 Schwaikheim
Leak testing device 3925-0075-00-00000000

Seq. no.	Pg	Date	Time	Measurement	Unit	Result	Error
1	1	06112003	084713	1	Pascal	Accept	0
2	1	06112003	084728	0	Pascal	Accept	0
3	1	06112003	084742	0	Pascal	Accept	0
4	1	06112003	084758	0	Pascal	Accept	0
5	1	06112003	084820	0	Pascal	Accept	0
6	1	06112003	084837	0	Pascal	Accept	0
7	1	06112003	084852	0	Pascal	Accept	0
8	1	06112003	084908	294	Pascal	Reject	0
9	1	06112003	084928	68	Pascal	Accept	0
10	1	06112003	084942	69	Pascal	Accept	0
11	1	06112003	084958	122	Pascal	Rework	0
12	1	06112003	085013	-----	Pascal	Gross leak	0
13	1	06112003	085029	0	Pascal	Accept	0
14	1	06112003	085042	0	Pascal	Accept	0
15	1	06112003	085057	0	Pascal	Accept	0
16	1	06112003	085120	0	Pascal	Accept	0
17	1	06112003	085134	529	Pascal	Reject	0
18	1	06112003	085212	0	Pascal	Accept	0
19	1	06112003	085233	36	Pascal	Accept	0
20	1	06112003	085240	-----	Pascal	-----	4

etc. up to 50 test results per page.

Each page has a new page header.

Program parameters

HeMaTech Prüftechnik, Siemensstraße 7, 71409 Schwaikheim

Leak testing device 3925-0075-00-10000000

Program number _____ : 1
Program name _____ : Hydraulic space
Work piece _____ : Dosing unit
Operator _____ : Mueller
Last change _____ : 06012010
Print date _____ : 06012010

Fill pressure _____ : 1.00 bar ON
Underfill pressure ___ : 0.80 bar
Test pressure _____ : 0.90 bar ON
Pressure tolerance ___ : 1.0 %

Filling time _____ : 3.00 sec
Underfilling time ___ : 0.30 sec
Stabilizing time ____ : 3.00 sec
Pause _____ : 1.00 sec
Auto zero _____ : 0.50 sec
Measuring _____ : 3.00 sec
Vent time _____ : 1.00 sec On
Vent if NOK. _____ : On

Rework from _____ :000100 Pascal On
Reject from _____ :000200 Pascal

Counter state Accept ___ : 15
Counter Total _____ : 19

Fixture offset _____ :000000 Pascal
Volume multiplier ____ : -.-----
Series error at _____ : 5

Envelope tolerance ___ : 1.00 % Off
Envelope Start _____ : 0.00 sec
Envelope end _____ : 3.00 sec

Data collection

HeMaTech Prüftechnik, Siemensstraße 7, 71409 Schwaikheim

Leak testing device 3925-0075-00-10000000

Seq. no.	Pg	Date	Time	Measurement	Unit	Result	Error
1	1	06112003	085240	-----	Pascal	ERROR04	
2	1	06112003	085233	36	Pascal	Accept	
3	1	06112003	085212	0	Pascal	Accept	
4	1	06112003	085134	529	Pascal	Reject	
5	1	06112003	085120	0	Pascal	Accept	
6	1	06112003	085057	0	Pascal	Accept	
7	1	06112003	085042	0	Pascal	Accept	
8	1	06112003	085029	0	Pascal	Accept	
9	1	06112003	085013	-----	Pascal	Gross leak	
10	1	06112003	084958	122	Pascal	Rework	
11	1	06112003	084942	69	Pascal	Accept	
12	1	06112003	084928	68	Pascal	Accept	
13	1	06112003	084908	294	Pascal	Reject	
14	1	06112003	084852	0	Pascal	Accept	
15	1	06112003	084837	0	Pascal	Accept	
16	1	06112003	084820	0	Pascal	Accept	
17	1	06112003	084758	0	Pascal	Accept	
18	1	06112003	084742	0	Pascal	Accept	
19	1	06112003	084728	0	Pascal	Accept	
20	1	06112003	084713	1	Pascal	Accept	

etc. up to 50 tests/page

Appendix

This section gives an overview of the plug assignment, pneumatic diagram, data output formats and examples, fieldbus data formats, declaration of conformity, technical data and available accessories.

Data output formats

USB:

Export test program

- Line printer
- Backup

Export Sequencer:

- Line printer
- Backup

Export stored results:

- File 01
- File 02
- Line printer
- Filling curve (text)
- Filling curve (image)

Serial interface:

Export test program

- Line printer

Export Sequencer:

- Line printer

Export stored results:

- File 01
- File 02
- Line printer
- Filling curve (text)

Examples

File 01: DPG20100200_F01.csv

DPG: Leak Tester
20100200: Serial number of the device
F01: File 01
csv: CSV format

File 02: DPG20100200_F02.csv

DPG: Leak Tester
20100200: Serial number of the device
F02: File 02
csv: CSV format

Line printer: DPG20100200_LPR.txt

DPG: Leak Tester
20100200: Serial number of the device
LPR: Line printer format
txt: Text file

Filling curve (text): DPG20100200_ENV.csv

DPG: Leak Tester
20100200: Serial number of the device
ENV: Envelope
csv: CSV format

Filling curve (image): DPG20100200_00000004_ENV.png

DPG: Leak Tester
20100200: Serial number of the device
00000004: Sequential number
ENV: Envelope
png: png format

Backup: DPG20100200_BACKUP_20201012094003.dpgDat

DPG: Leak Tester
20100200: Serial number of the device
BACKUP: Backup
20201012094003: Date and time
dpgDat: Data safety file

Data format fieldbus

Module	Measurement result output part 1		
Type	Byte/Bit	3925-0075 LEAK TESTER	Data type
Data output	Byte 0	SeqNo. digit 1	
Data output	Byte 1	SeqNo. digit 2	
Data output	Byte 2	SeqNo. digit 3	
Data output	Byte 3	SeqNo. digit 4	
Data output	Byte 4	SeqNo. digit 5	
Data output	Byte 5	SeqNo. digit 6	
Data output	Byte 6	SeqNo. digit 7	
Data output	Byte 7	SeqNo. digit 8	
Data output	Byte 8	SeqNo. Semicolon	
Data output	Byte 9	Program number digit 1	
Data output	Byte 10	Program number digit 2	
Data output	Byte 11	Program number semicolon	
Data output	Byte 12	Day digit 1	
Data output	Byte 13	Day digit 2	
Data output	Byte 14	Month digit 1	
Data output	Byte 15	Month digit 2	
Data output	Byte 16	Year digit 1	
Data output	Byte 17	Year digit 2	
Data output	Byte 18	Year digit 3	
Data output	Byte 19	Year digit 4	
Data output	Byte 20	Day/Month/Year semicolon	
Data output	Byte 21	Hour digit 1	
Data output	Byte 22	Hour digit 2	
Data output	Byte 23	Minute digit 1	
Data output	Byte 24	Minute digit 2	
Data output	Byte 25	Second digit 1	
Data output	Byte 26	Second digit 2	
Data output	Byte 27	Hour/minute/second semicolon	
Data output	Byte 28	Measuring value with digit 1	
Data output	Byte 29	Measuring value with digit 2	
Data output	Byte 30	Measuring value with digit 3	
Data output	Byte 31	Measuring value with digit 4	
Data output	Byte 32	Measuring value with digit 5	
Data output	Byte 33	Measuring value with digit 6	
Data output	Byte 34	Measurement semicolon	
Data output	Byte 35	Unit digit 1	

Module	Measurement result output part 1	
Data output	Byte 36	Unit digit 2
Data output	Byte 37	Unit semicolon
Data output	Byte 38	Result 1 digit
Data output	Byte 39	Result 2 digit
Data output	Byte 40	Result semicolon
Data output	Byte 41	Error number digit 1
Data output	Byte 42	Error number digit 2
Data output	Byte 43	Error number semicolon
Data output	Byte 44	Test pressure with digit 1
Data output	Byte 45	Test pressure with digit 2
Data output	Byte 46	Test pressure with digit 3
Data output	Byte 47	Test pressure with digit 4
Data output	Byte 48	Test pressure with digit 5
Data output	Byte 49	Test pressure with digit 6
Data output	Byte 50	Test pressure semicolon
Data output	Byte 51	Measuring time with digit 1
Data output	Byte 52	Measuring time with digit 2
Data output	Byte 53	Measuring time with digit 3
Data output	Byte 54	Measuring time with digit 4
Data output	Byte 55	Measuring time with digit 5
Data output	Byte 56	Measuring time with digit 6
Data output	Byte 57	Measurement time semicolon
Data output	Byte 58	Volume factor with digit 1
Data output	Byte 59	Volume factor with digit 2
Data output	Byte 60	Volume factor with digit 3
Data output	Byte 61	Volume factor with digit 4
Data output	Byte 62	Volume factor with digit 5
Data output	Byte 63	Volume factor with digit 6

Module		Measurement result output part 2	
Type	Byte/Bit	3925-0075 LEAK TESTER	Data type
Data output	Byte 0	Volume factor with digit 7	
Data output	Byte 1	Volume factor with digit 8	
Data output	Byte 2	Volume factor semicolon	
Data output	Byte 3	Rework digit 1	
Data output	Byte 4	Rework digit 2	
Data output	Byte 5	Rework digit 3	
Data output	Byte 6	Rework digit 4	
Data output	Byte 7	Rework digit 5	
Data output	Byte 8	Rework digit 6	
Data output	Byte 9	Rework semicolon	
Data output	Byte 10	Reject digit 1	
Data output	Byte 11	Reject digit 2	
Data output	Byte 12	Reject digit 3	
Data output	Byte 13	Reject digit 4	
Data output	Byte 14	Reject digit 5	
Data output	Byte 15	Reject digit 6	

Module	Input Transfer parameter		
Type	Byte/Bit	3925-0075 LEAK TESTER	Data type
Input data	Byte 0	Parameter ID digit 1	UINT 16
Input data	Byte 1	Parameter ID digit 2	UINT 16
Input data	Byte 2	Parameter max. length string (50 char.)	UINT 8
Input data	Byte 3	Parameter current length string	UINT 8
Input data	Byte 4	Parameter digit 1	UINT 8
Input data	Byte 5	Parameter digit 2	UINT 8
Input data	Byte 6	Parameter digit 3	CHAR
Input data	Byte 7	Parameter digit 4	CHAR
Input data	Byte 8	Parameter digit 5	CHAR
Input data	Byte 9	Parameter digit 6	CHAR
Input data	Byte 10	Parameter digit 7	CHAR
Input data	Byte 11	Parameter digit 8	CHAR
Input data	Byte 12	Parameter digit 9	CHAR
Input data	Byte 13	Parameter digit 10	CHAR
Input data	Byte 14	Parameter digit 11	CHAR
Input data	Byte 15	Parameter digit 12	CHAR
Input data	Byte 16	Parameter digit 13	CHAR
Input data	Byte 17	Parameter digit 14	CHAR
Input data	Byte 18	Parameter digit 15	CHAR
Input data	Byte 19	Parameter digit 16	CHAR
Input data	Byte 20	Parameter digit 17	CHAR
Input data	Byte 21	Parameter digit 18	CHAR
Input data	Byte 22	Parameter digit 19	CHAR
Input data	Byte 23	Parameter digit 20	CHAR
Input data	Byte 24	Parameter digit 21	CHAR
Input data	Byte 25	Parameter digit 22	CHAR
Input data	Byte 26	Parameter digit 23	CHAR
Input data	Byte 27	Parameter digit 24	CHAR
Input data	Byte 28	Parameter digit 25	CHAR
Input data	Byte 29	Parameter digit 26	CHAR
Input data	Byte 30	Parameter digit 27	CHAR
Input data	Byte 31	Parameter digit 28	CHAR
Input data	Byte 32	Parameter digit 29	CHAR
Input data	Byte 33	Parameter digit 30	CHAR
Input data	Byte 34	Parameter digit 31	CHAR
Input data	Byte 35	Parameter digit 32	CHAR
Input data	Byte 36	Parameter digit 33	CHAR
Input data	Byte 37	Parameter digit 34	CHAR

Module	Input Transfer parameter		
Type	Byte/Bit	3925-0075 LEAK TESTER	Data type
Input data	Byte 38	Parameter digit 35	CHAR
Input data	Byte 39	Parameter digit 36	CHAR
Input data	Byte 40	Parameter digit 37	CHAR
Input data	Byte 41	Parameter digit 38	CHAR
Input data	Byte 42	Parameter digit 39	CHAR
Input data	Byte 43	Parameter digit 40	CHAR
Input data	Byte 44	Parameter digit 41	CHAR
Input data	Byte 45	Parameter digit 42	CHAR
Input data	Byte 46	Parameter digit 43	CHAR
Input data	Byte 47	Parameter digit 44	CHAR
Input data	Byte 48	Parameter digit 45	CHAR
Input data	Byte 49	Parameter digit 46	CHAR
Input data	Byte 50	Parameter digit 47	CHAR
Input data	Byte 51	Parameter digit 48	CHAR
Input data	Byte 52	Parameter digit 49	CHAR
Input data	Byte 53	Parameter digit 50	CHAR
Input data	Byte 54	Reserve	CHAR
Input data	Byte 55	Reserve	CHAR
Input data	Byte 56	Reserve	CHAR
Input data	Byte 57	Reserve	CHAR
Input data	Byte 58	Reserve	CHAR
Input data	Byte 59	Reserve	CHAR
Input data	Byte 60	Reserve	CHAR
Input data	Byte 61	Reserve	CHAR
Input data	Byte 62	Reserve	CHAR
Input data	Byte 63	Reserve	CHAR

Module		Output Parameter Transfer	
Type	Byte/Bit	3925-0075 LEAK	Data type
Data output	Byte 0	Parameter mirror ID digit 1	UINT 16
Data output	Byte 1	Parameter mirror ID digit 2	UINT 16
Data output	Byte 2	Parameter mirror max. length string (50 char.)	UINT 8
Data output	Byte 3	Parameter mirror actual length string	UINT 8
Data output	Byte 4	Parameter mirror digit 1	UINT 8
Data output	Byte 5	Parameter mirror digit 2	UINT 8
Data output	Byte 6	Parameter mirror digit 3	CHAR
Data output	Byte 7	Parameter mirror digit 4	CHAR
Data output	Byte 8	Parameter mirror digit 5	CHAR
Data output	Byte 9	Parameter mirror digit 6	CHAR
Data output	Byte 10	Parameter mirror digit 7	CHAR
Data output	Byte 11	Parameter mirror digit 8	CHAR
Data output	Byte 12	Parameter mirror digit 9	CHAR
Data output	Byte 13	Parameter mirror digit 10	CHAR
Data output	Byte 14	Parameter mirror digit 11	CHAR
Data output	Byte 15	Parameter mirror digit 12	CHAR
Data output	Byte 16	Parameter mirror digit 13	CHAR
Data output	Byte 17	Parameter mirror digit 14	CHAR
Data output	Byte 18	Parameter mirror digit 15	CHAR
Data output	Byte 19	Parameter mirror digit 16	CHAR
Data output	Byte 20	Parameter mirror digit 17	CHAR
Data output	Byte 21	Parameter mirror digit 18	CHAR
Data output	Byte 22	Parameter mirror digit 19	CHAR
Data output	Byte 23	Parameter mirror digit 20	CHAR
Data output	Byte 24	Parameter mirror digit 21	CHAR
Data output	Byte 25	Parameter mirror digit 22	CHAR
Data output	Byte 26	Parameter mirror digit 23	CHAR
Data output	Byte 27	Parameter mirror digit 24	CHAR
Data output	Byte 28	Parameter mirror digit 25	CHAR
Data output	Byte 29	Parameter mirror digit 26	CHAR
Data output	Byte 30	Parameter mirror digit 27	CHAR
Data output	Byte 31	Parameter mirror digit 28	CHAR
Data output	Byte 32	Parameter mirror digit 29	CHAR
Data output	Byte 33	Parameter mirror digit 30	CHAR
Data output	Byte 34	Parameter mirror digit 31	CHAR
Data output	Byte 35	Parameter mirror digit 32	CHAR
Data output	Byte 36	Parameter mirror digit 33	CHAR
Data output	Byte 37	Parameter mirror digit 34	CHAR

Module		Output Parameter Transfer	
Type	Byte/Bit	3925-0075 LEAK	Data type
Data output	Byte 38	Parameter mirror digit 35	CHAR
Data output	Byte 39	Parameter mirror digit 36	CHAR
Data output	Byte 40	Parameter mirror digit 37	CHAR
Data output	Byte 41	Parameter mirror digit 38	CHAR
Data output	Byte 42	Parameter mirror digit 39	CHAR
Data output	Byte 43	Parameter mirror digit 40	CHAR
Data output	Byte 44	Parameter mirror digit 41	CHAR
Data output	Byte 45	Parameter mirror digit 42	CHAR
Data output	Byte 46	Parameter mirror digit 43	CHAR
Data output	Byte 47	Parameter mirror digit 44	CHAR
Data output	Byte 48	Parameter mirror digit 45	CHAR
Data output	Byte 49	Parameter mirror digit 46	CHAR
Data output	Byte 50	Parameter mirror digit 47	CHAR
Data output	Byte 51	Parameter mirror digit 48	CHAR
Data output	Byte 52	Parameter mirror digit 49	CHAR
Data output	Byte 53	Parameter mirror digit 50	CHAR
Data output	Byte 54	Reserve	CHAR
Data output	Byte 55	Reserve	CHAR
Data output	Byte 56	Reserve	CHAR
Data output	Byte 57	Reserve	CHAR
Data output	Byte 58	Reserve	CHAR
Data output	Byte 59	Reserve	CHAR
Data output	Byte 60	Reserve	CHAR
Data output	Byte 61	Reserve	CHAR
Data output	Byte 62	Reserve	CHAR
Data output	Byte 63	Reserve	CHAR

Technical Data

Program memory	NAND flash, permanent storage, up to 10,000 results
Measuring transducer	Temperature compensated measuring converter for differential pressure, with 1.4 barg pressure relief.
Measuring range	0 ... 3000 Pa,
Resolution	Display 1 Pa via high resolution SigmaDelta A/D converter
Measuring value display:	7" TFT-LCD display, 800x480 pixel Measuring value in Pa, mmWC, mbar, psi, mmHg, ml/min
Keyboard	Virtual keyboard via TFT-LCD touch display
Test programs	99
Filling and testing pressure	Electr. pressure setting 0.2 ... 6.0 barg
Test parameters	<p>Program number: Filling pressure: Underfilling pressure: Test pressure: Pressure tolerance: 1.0 ... 10.0 % v.E. Filling time: 0.1 ... 999.9 sec, Underfilling time: 0.1 ... 9.99 sec, Stabilisation time: 0.1 ... 999.9 sec, Measuring time: 0.1 ... 999.9 sec, Venting time: 0.1 ... 999.9 sec, Measuring value unit: Pa, mmWC, mbar, psi, mmHG, ml/min, Tare of device: Volume factor: -.-.-.- Rework from ... Rework from ... ON/OFF Reject from ... Reject from ... ON/OFF Series fault from: x parts leaky or gross leak</p>
Write-protection	via key switch
Result signals	Accept, Rework and Reject

Interfaces	1 parallel interface (machine control) (maximum 96 digital inputs/outputs)
Control inputs	1 bit each for Automatic, Machine ready, Start, Flooding and Abort 8 bit program selection
Control outputs	1 bit each for Ready for operation, Ready for test, error, No leak, Rework, Leak, Measuring
Serial interface	RS 232C for parameter and measurement transfer
Fieldbus interface (optional)	Profibus, Profinet for parameter and measurement transfer and/or to external controls.
USB interface	USB 2.0 for parameter and measurement transfer Connection for keyboard and mouse
RJ45	VNC
Structure	Compact housing
Dimensions	The device dimensions W × H × D are: 357 × 142 × 420 mm
Electric power supply	100-240 V, 50/60 Hz (without system transfer)
Device protection	Fuse unit 1× 2.0 AT (5 × 20 mm slow) Order-number: 8834-0313
Power input	maximum 100 VA
Supply air	min. 1.5 bar/a > test pressure, max. 10 barg, dry, oil free and filtered
Connections	Supply air connection G ¼"
	Test connection G ⅛"
Venting	via silencer G ¼"
Weight	approx. 8 kg
Order-number	3925-0075

(Subject to alterations)

** Option

List of figures

Figure 1: Function schematic of differential pressure test.....	14
Figure 2: Pressure course in the test system during the test process.....	15
Figure 3: Device view, front.....	19
Figure 4: Device view, rear.....	20
Figure 5: Start screen	26
Figure 6: Main menu with the fieldbus symbol in the menu bar	26
Figure 7: Main menu after initialisation.....	27
Figure 8: Dialog window main menu.....	31
Figure 9: Dialog window Automatic.....	31
Figure 10: Dialog window filling curve view	32
Figure 11: Dialog window Automatic step	33
Figure 12: Dialog window Main menu - Manual	35
Figure 13: Dialog window Manual - Program selection.....	36
Figure 14: Dialog window Manual - Test	36
Figure 15: Dialog window Manual testing.....	37
Figure 16: Dialog window Manual Testing with Leak	38
Figure 17: Dialog window Manual testing with activated leak simulation.....	38
Figure 18: Dialog window Manual testing - Filling curve.....	39
Figure 19: Dialog window Manual test sequence	40
Figure 20: Dialog window Error 39.....	41
Figure 21: Dialog window Error 39 acknowledged.....	41
Figure 22: Dialog window Save reference curve	42
Figure 23: Dialog window - Sequencer Automatic/Manual	43
Figure 24: Dialog window, Manual flooding.....	44
Figure 25: Dialog window Manual flooding - Ready for flooding	45
Figure 26: Dialog window, Manual flooding - Flooding	46
Figure 27: Dialog window Setup.....	47
Figure 28: Dialog window Set up - Test program.....	47
Figure 29: Dialog window Set up test program.....	49
Figure 30: Dialog window Test program set up measurement unit.....	51
Figure 31: Dialog window Unsaved changes	54
Figure 32: Data output test program	55
Figure 33: Dialog window Context menu test program	56
Figure 34: Dialog window Data export test program	56
Figure 35: Dialog window Copy test program	58
Figure 36: Dialog window Save test program as.....	58
Figure 37: Dialog window Set up Sequencer	59
Figure 38: Dialog window data output Sequencer.....	60
Figure 39: Dialog window data output Sequencer.....	61
Figure 40: Dialog window Set up 1st Serial interface.....	62
Figure 41: Dialog window - Output of file format - File 01.....	64
Figure 42: Dialog window - Output the data format - File02.....	67

Figure 43: Dialog window Setting up interfaces - Profibus.....	69
Figure 44: Dialog window Setting up interfaces - Profinet.....	70
Figure 45: Dialog window Setting up interfaces - TCP/IP v4.....	82
Figure 46: Dialog window Setting up interfaces - TCP/IP v6.....	83
Figure 47: Dialog window Set up TCP/IP for a VNC server.....	84
Figure 48: Dialog window File menu – Data collection.....	85
Figure 49: Dialog window Main menu Login window.....	86
Figure 50: Dialog window Login VNC server.....	87
Figure 51: Dialog window user level 5 main menu.....	87
Figure 52: Dialog window edit Rights.....	88
Figure 53: Dialog window Change password user level 5.....	88
Figure 54: Dialog window Setting up interfaces - USB.....	89
Figure 55: Dialog window System status settings.....	90
Figure 56: Dialog window System parameter settings.....	91
Figure 57: Dialog window System parameter settings System data.....	91
Figure 58: Dialog window Settings software version.....	92
Figure 59: Dialog window Settings Options.....	93
Figure 60: Dialog window Display settings.....	95
Figure 61: Dialog window Date & Time settings.....	96
Figure 62: Dialog window Settings Software update.....	97
Figure 63: Dialog window Settings Software update - Execute update.....	97
Figure 64: Dialog window adjust settings of pressure system.....	98
Figure 65: Dialog window adjust pressure system settings - Pressure adjustment.....	98
Figure 66: Dialog window Adjust pressure system settings - Pressure adjustment successful....	99
Figure 67: Dialog window Stabilise pressure system settings - Error 27.....	99
Figure 68: Dialog window data.....	100
Figure 69: Dialog window Data program overview.....	100
Figure 70: Dialog window Data collection.....	101
Figure 71: Dialog window Data results storage filling curve.....	101
Figure 72: Dialog window Data - Data export.....	102
Figure 73: Dialog window Data Operating Data.....	103
Figure 74: Dialog window, reset the Data operating data counter.....	103
Figure 75: Dialog window Data - Data export.....	104
Figure 76: Dialog window Data - Data Export - Export data.....	105
Figure 77: Dialog window Data Data import.....	106
Figure 78: Dialog window Data Data import.....	107
Figure 79: Dialog window Data - data import programs selected.....	107
Figure 80: Dialog window Start data import.....	108
Figure 81: Dialog window Data - Data Import active.....	108
Figure 82: Dialog window Data - Data Import completed.....	109
Figure 83: Dialog window Manual testing Result Accept.....	111
Figure 84: Test leak with Stäubli plug-in nipple.....	151
Figure 85: Test leak with G1/8" thread.....	151
Figure 86: Leak calibration device.....	152
Figure 87: Manual control panel.....	153
Figure 88: Switch unit 2-times with manual operation via the front button.....	154

EC - Declaration of Conformity**EG – KONFORMITÄTSERKLÄRUNG**

EC DECLARATION OF CONFORMITY
 ATTESTATION DE CONFORMITE C.E.

Produktbezeichnung: Dichtheitsprüfgerät 3925-0075
 Product name: Typen- Nr.: 3925-0075
 Désignation du produit:

Das Produkt stimmt mit den Vorschriften folgender Europäischer Richtlinien überein:
 This product meet the requirements of the following European directives:
 Les produits répondent aux exigences des Directives C.E. suivantes:

2014/30/EU	EMV – Richtlinie * Electromagnetic Compatibility * Directives concernant la compatibilité électromagnétique *
2014/35/EU	Niederspannungsrichtlinie * EC -Low -Voltage Directive * Directives concernant la basse tension *

* einschließlich Änderungen und Umsetzung durch das EMVG und Gerätesicherheitsgesetz
 * including alterations and German realization by the EMC law and the instruments safety law
 * y compris les modifications et la réalisation allemande par la loi concernant la compatibilité électromagnétique et la sécurité d'appareils

Die Übereinstimmung mit den Vorschriften dieser Richtlinien wird nachgewiesen durch die Einhaltung der folgenden Normen:

Conformity with the requirements of these Directives is proven by complete adherence to the following standards:
 La conformité avec les exigences de ces directives est prouvée par l'observation complète des normes suivantes:

EN IEC 61000-6-3:2021 / EN IEC 61000-6-4:2019 / EN 61010-1:2010 + A1:2019 + A1:2019/AC:2019 / EN IEC 61000-4-3:2020 / EN 61000-4-2:2009

Diese Erklärung wird gegeben von:
 This declaration is given of:
 Cette attestation est donnée de:

HeMaTech Prüftechnik GmbH & Co. KG
 Siemenstrasse 7
 D 71409 Schwaikheim
 Harald Hellerich

Geschäftsführer

Schwaikheim, 15.05.2023



Index

A	
Automatic	30
Automatic operation	
Flooding.....	34
Sequencer	33
without leak simulation.....	34
B	
Backup	30
C	
Code for measuring result.....	65
Command bar	27
Connecting compressed air.....	21, 22
Connecting test medium	21
Connecting the machine control.....	23
Connecting the reference volume	22
Connecting the specimen.....	22
Connecting the supply air.....	22
Connections	20
Contact address	155
Control commands	30
Copying a test program	58
D	
Data bits	63
Data exchange.....	17
Date & Time.....	30
Datei02	67
Decimal places mbar	100
Decimal places Pa.....	100
Decimal places psi.....	100
Device design.....	18
Differential pressure method.....	14
Display	30
E	
EC - Declaration of Conformity.....	152
Edit the number of sequencer cycles.....	59
Edit the pause time.....	59
Electronics	18
Enter serial error.....	52
EnvelopStart.....	53
EnvelopTolerance	53
Error 00.....	122
Error 01	122
Error 03	33, 122
Error 04	122
Error 10	123
Error 13	123
Error 14	124
Error 15	124
Error 16	124
Error 19	124
Error 20	124
Error 23	124
Error 24	124
Error 25	125
Error 26	125
Error 27	125
Error 28	125
Error 37	125
Error 38	125
Error 39	126
Error 40	33, 44, 126
Error number	66
Exceeding a value	66
F	
Filling.....	15
Flooding.....	30
Automatic.....	34
Format.....	63
Front view.....	19
Function monitoring.....	17
I	
Installation.....	12
Intended use	8
Interfaces	30
Intervention limit	
for Reject	53
for Rework.....	53
L	
LC-Display.....	19
M	
Main menu.....	30, 31
Maintenance.....	12

Manual.....	30	Repair	12
Manual operation.....	35	Result counter.....	30
Measuring.....	15	Result memory.....	30
Measuring data		Result signals.....	17
of File01.....	64		
of File02.....	67	S	
Measuring result, code.....	65	Safety notes.....	13
Model designation	8	Scope of delivery.....	18
		Sequencer.....	33, 59
N		Sequencer cycles.....	59
Number of decimal places ml/min	101	Sequencer pause time.....	59
Number of decimal places mmHg	100	Sequencer setup.....	59
Number of decimal places mmWS	100	Serial #1.....	30
Number of test programs.....	17	Serial #2.....	30
		Serial #3.....	30
O		Serial #4.....	30
Operating data.....	30	Serial number	8
Operation.....	12	Setting up a PC interface.....	64
Operation mode		Settings.....	30
Automatic	31	Setup	
Manual	35	Interface Ser #2	69, 70, 88
Options	30	Profibus interface Ser #2.....	69, 70, 88
Ordering spare parts.....	8	Setup parameter set	47
		Showing the Error Counter Status.....	30
P		Software-Version.....	8
Parameter set.....	30	Stabilising.....	15
Parity.....	63	Start-up.....	21
Performance characteristics.....	17	Status field	19
Peripheral equipment	21	Stop bits	63
Plug assignment.....	138	Sub-D socket	20
Pneumatic diagram		Supply air connection	20
Over-pressure.....	139	Symbols.....	12
Pneumatics	18	System parameters	30
Pressure control	30	System status.....	30
Print Menu	30		
Product description.....	13	T	
Profibus.....	30	Test.....	30
Functions	69, 70	Test medium	14
Inputs and outputs.....	71	Test programs	17
PLC07v100.GSD	70, 71	Setup.....	47
Protocol.....	63	Testing process.....	15
		Transport damage	8
R		Type plate	8, 20
Record.....	30		
Record Reference.....	30	V	
Reference.....	30	View of device	19
		View Program Status.....	30

	W	
Warranty.....	9	Working principle..... 18
		Write protection switch..... 19

Contact address:

HeMaTech Prüftechnik GmbH & Co. KG
Siemensstrasse 7
D-71409 Schwaikheim
Telephone +49 (0) 71 95/13 69- 0
Fax +49 (0) 71 95/13 69- 29
Internet <http://www.hematech.de>

Notes:

Accessories

Leak simulation

Part no. 3925-2041

There are different components and options for using the leak simulation.

Test leak

- A defined leak for a fixed pressure that can be connected to the leak tester in different ways.



Figure 84: Test leak with Stäubli plug-in nipple

For a test leak with a Stäubli plug-in nipple, a corresponding Stäubli coupling (Part no. 3925-2051) is required on the leak test device.

Use

- The test leak is plugged into the plug-in nipple into the Stäubli coupling on the leak test device before starting the test

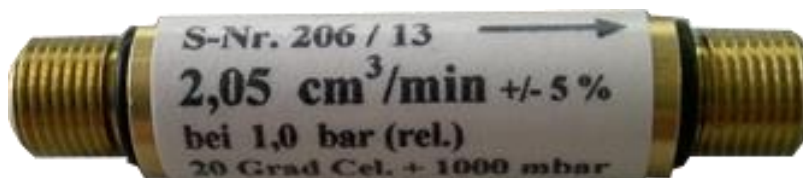

Figure 85: Test leak with G1/8" thread

- For a test leak with a G 1/8" thread

Use

- The test leak is screwed into a corresponding adapter or connector to the G 1/8" thread before starting the test.

Leak calibration device

Part no. 3925-0202

- A variable leak for a pressure range of 0-8 bar that can be connected in different ways to the leak test device.



Figure 86: Leak calibration device

Manual control panel

Part no. 3925-0409

The manual control panel gives the user a range of functions and options to control the leak test device from HeMaTech Prüftechnik GmbH & Co. KG.



Figure 87: Manual control panel

Performance characteristics

99 test programs

You can select one of the 99 different test programs and they can be started via the manual control panel.

Abort

There is an option to abort the test sequence by using the "Abort" button

Leak simulation

There is an option to switch on leak simulation before starting the test cycle

Flooding

There is an option to manually load the test piece with test pressure by using the Flooding function.

Result signals

The device shows several results:

- Accept
- Rework
- Leak
- Fault

Switching unit

Part no. 3925-045x

To use a leak test device with several fixtures, a switching unit can be used so sequential multi-digit measurements can be done.

There are various kinds of switching units, max. 6 measurement points are possible in one switching unit.



Figure 88: Switch unit 2-times with manual operation via the front button